

Appendix E

Contingency Plan

**Former Gulf States Creosoting Site
Hattiesburg, Mississippi**

Contingency Plan

**Former Gulf States Creosoting Site
Hattiesburg, Mississippi**

August 12, 2002

Project No. 21-04

MICHAEL PISANI & ASSOCIATES, INC.

Environmental Management and Engineering Services

1100 Poydras Street

1430 Energy Centre

New Orleans, Louisiana 70163

(504) 582-2468

**Table of Contents
Contingency Plan**

**Former Gulf States Creosoting Site
Hattiesburg, Mississippi**

	Page
1.0 Introduction	1
2.0 Existing Ground Water Monitoring Network	1
3.0 Contingency Plan	5
4.0 Financial Assurance	5

Figures

- 2-1 Existing Ground Water Monitoring Wells as of December 2001**
- 2-2 Approximate Extent of Affected Ground Water – Process Area and Northeast Drainage Ditch**
- 2-3 Approximate Extent of Affected Ground Water – Fill Area**

Tables

- 4-1 Estimated Probable Costs – Ground Water Monitoring and Post-Closure Inspections**

Contingency Plan

Former Gulf States Creosoting Site Hattiesburg, Mississippi

1.0 Introduction

This *Contingency Plan* has been developed at the request of the Mississippi Department of Environmental Quality (MDEQ) to respond to the potential migration of existing ground water contaminant plumes at the former Gulf States Creosoting Site in Hattiesburg, Mississippi. Kerr-McGee Chemical, L.L.C. (KMC) has completed a Remedial Investigation (RI) at the site, and the extent of affected ground water has been fully delineated. The results of a human health risk assessment indicate that there is no current risk associated with affected ground water, as shallow ground water in the vicinity of the site is unused for any purpose.

Section 2.0 of this plan provides background information on the existing ground water monitoring network. Procedures that will be implemented in response to the migration of existing plumes are established in Section 3.0. Section 4.0 presents information requested by MDEQ regarding financial assurance required to conduct ongoing ground water monitoring at the site.

2.0 Existing Ground Water Monitoring Network

Currently, a network of 24 ground water monitoring wells exists to monitor site ground water conditions. The locations of these wells are depicted on Figure 2-1. During completion of the RI, temporary well points and ground water monitoring wells were used to delineate the extent of affected ground water. The RI results established that three distinct contaminant plumes are present at the site: One associated with the former Process Area, one associated with the Gordon's Creek Fill Area, and one associated with the northeast drainage ditch.

As part of the ongoing ground water monitoring program, wells within, upgradient of, and downgradient of each plume are routinely sampled for polycyclic aromatic hydrocarbons (PAHs). Due to its solubility, naphthalene is the only target constituent that migrates significant distance from source area. The extent of naphthalene in the Process Area plume and the northeast drainage ditch plume is depicted on Figure 2-2; the extent of naphthalene in the Fill Area is depicted on Figure and 2-3.

Plume-defining wells are as follows:

- Process Area plume: MW-16, MW-08, and MW-18;
- Northeast drainage ditch plume: MW-20, MW-21, and MW-22; and
- Fill Area plume: MW-13, MW-14, and MW-15.

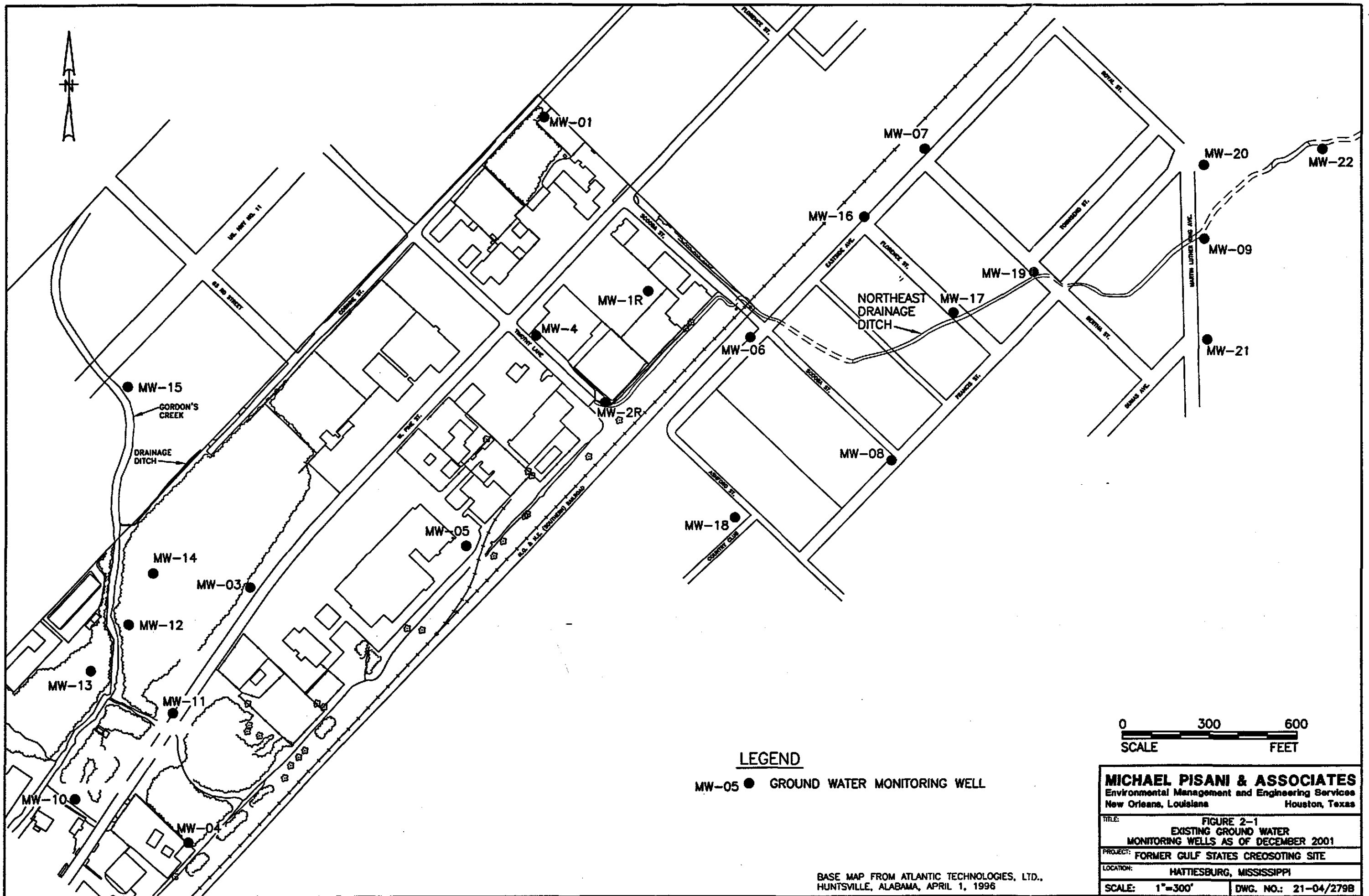

LEGEND

MW-05 ● GROUND WATER MONITORING WELL

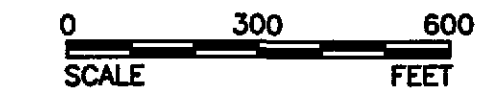

MICHAEL PISANI & ASSOCIATES	
Environmental Management and Engineering Services New Orleans, Louisiana Houston, Texas	
TITLE: FIGURE 2-1 EXISTING GROUND WATER MONITORING WELLS AS OF DECEMBER 2001	
PROJECT: FORMER GULF STATES CREOSOTING SITE	
LOCATION: HATTIESBURG, MISSISSIPPI	
SCALE: 1"=300'	DWG. NO.: 21-04/2798

BASE MAP FROM ATLANTIC TECHNOLOGIES, LTD.,
HUNTSVILLE, ALABAMA, APRIL 1, 1996

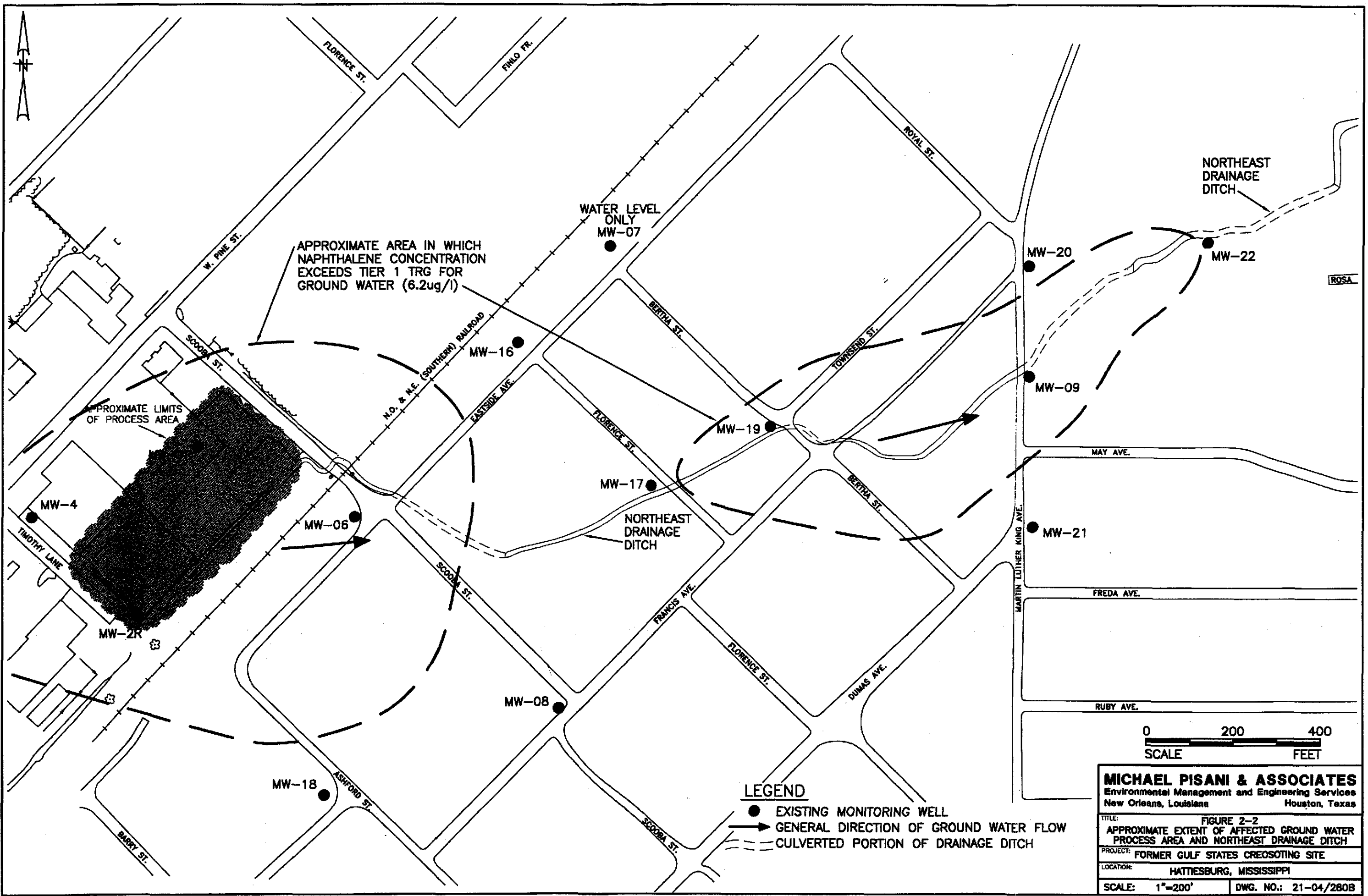

APPROXIMATE AREA IN WHICH NAPHTHALENE CONCENTRATION EXCEEDS TIER 1 TRG FOR GROUND WATER (6.2ug/l)

APPROXIMATE LIMITS OF PROCESS AREA

WATER LEVEL ONLY MW-07

NORTHEAST DRAINAGE DITCH

MW-20

MW-22

MW-16

MW-09

MW-19

MW-17

NORTHEAST DRAINAGE DITCH

MW-21

MW-4

MW-06

FREDA AVE.

MW-2R

MW-08

RUBY AVE.

MW-18

LEGEND

- EXISTING MONITORING WELL
- ➔ GENERAL DIRECTION OF GROUND WATER FLOW
- - - CULVERTED PORTION OF DRAINAGE DITCH



MICHAEL PISANI & ASSOCIATES
Environmental Management and Engineering Services
New Orleans, Louisiana Houston, Texas

TITLE:	FIGURE 2-2 APPROXIMATE EXTENT OF AFFECTED GROUND WATER PROCESS AREA AND NORTHEAST DRAINAGE DITCH	
PROJECT:	FORMER GULF STATES CREOSOTING SITE	
LOCATION:	HATTIESBURG, MISSISSIPPI	
SCALE:	1"=200'	DWG. NO.: 21-04/280B

Table 4-1

**Estimated Probable Costs
Ground Water Monitoring and Post-Closure Inspections**

**Gulf States Creosoting Site
Hattiesburg, Mississippi**

Estimated June 2002; Effective January 1, 2003

Task	Annual Cost	Number of Years	Total Cost
1. Quarterly Ground Water Monitoring (years 2; year 1 almost complete)	\$60,000	1	\$60,000
2. Annual Ground Water Monitoring (Sample collection and analysis) (years 3 through 30)	\$15,000	28	\$420,000
3. Annual Report Preparation (years 1 through 30)	\$2,500	30	\$75,000
4. Annual Inspections (containment and phytoremediation system) (years 1 through 30)	\$3,000	30	\$90,000
Total Estimated Costs (30 Years)			\$645,000

Monitoring results from these plume-defining wells will be evaluated to demonstrate that existing contaminant plumes have achieved steady state conditions, as believed, or are continuing to grow.

3.0 Contingency Plan

For the first two years of ground water monitoring (2002 and 2003), samples are being collected on a quarterly basis. During this time, should target constituents be detected in plume-defining wells at concentrations exceeding MDEQ Tier 1 Target Remediation Goals (TRGs) for three consecutive sampling events, KMC will, within 60 days, submit a plan for assessment activities at the specific wells impacted for MDEQ review and approval. At the completion of assessment activities, KMC will submit a report documenting assessment results and proposing appropriate further action, as required.

After the first two years of monitoring, should data indicate that ground water contaminants are not migrating, KMC will modify the program to monitor ground water annually. If, after the monitoring frequency is decreased, a well exhibits concentrations exceeding Tier 1 TRGs, the monitoring frequency for that well will revert to quarterly until Tier 1 TRGs are not exceeded for three consecutive quarters.

4.0 Financial Assurance

KMC is providing financial assurance for ongoing ground water monitoring activities. Estimated probable costs for 30 years of ground water monitoring and post-closure inspection of the caps, barriers, and phytoremediation system are provided in Table 1. KMC will provide financial assurance for ongoing ground water monitoring activities starting with the first quarter of 2003.

Should the ground water remedy for the site change from monitored natural attenuation to an active remedy, KMC will consult with MDEQ and will provide additional financial assurance, as appropriate.

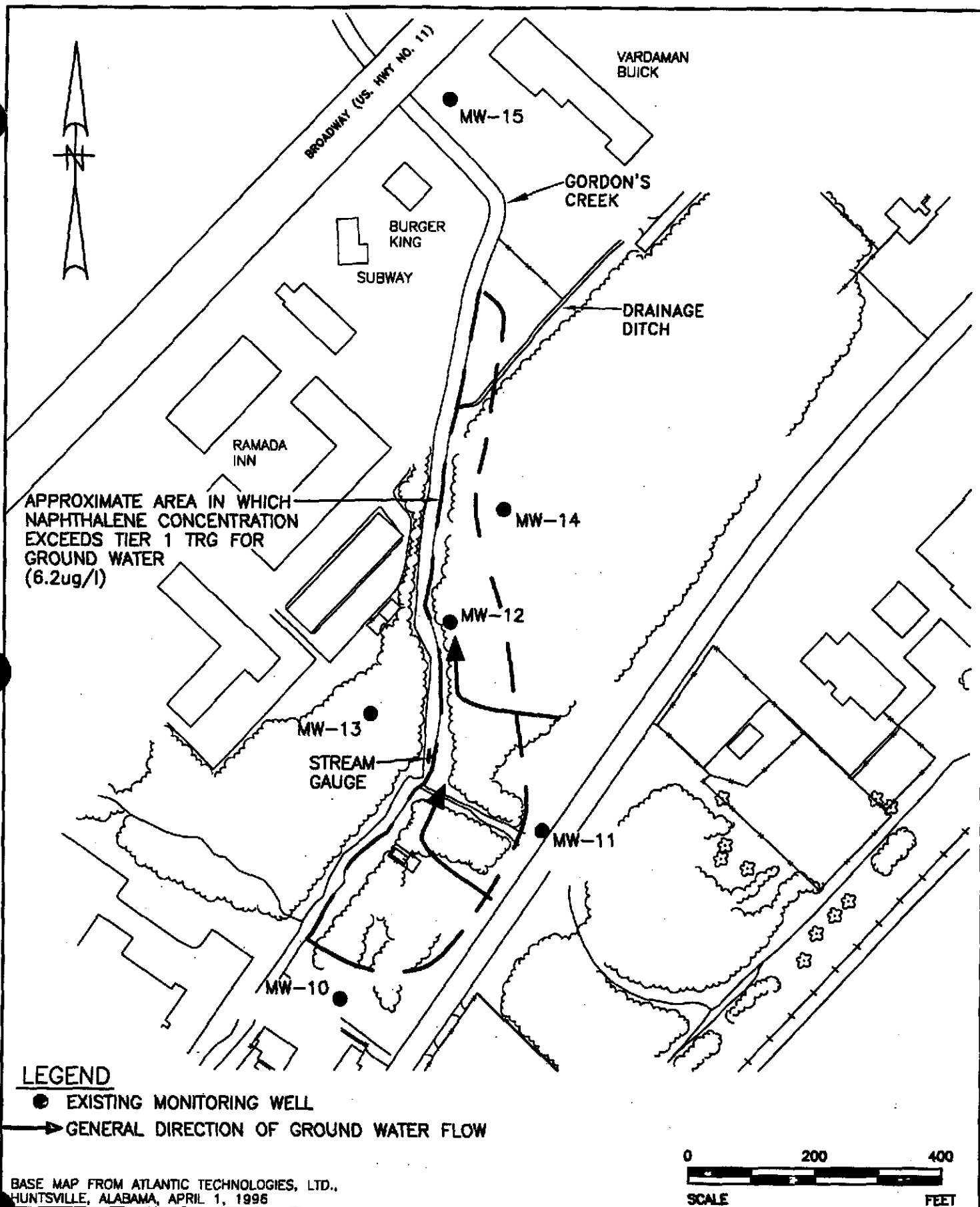

APPROXIMATE AREA IN WHICH NAPHTHALENE CONCENTRATION EXCEEDS TIER 1 TRG FOR GROUND WATER (6.2ug/l)

LEGEND

- EXISTING MONITORING WELL
- ➔ GENERAL DIRECTION OF GROUND WATER FLOW



BASE MAP FROM ATLANTIC TECHNOLOGIES, LTD., HUNTSVILLE, ALABAMA, APRIL 1, 1996

MICHAEL PISANI & ASSOCIATES
 Environmental Management and Engineering Services
 New Orleans, Louisiana Houston, Texas

SCALE: 1"=200' DWG. NO.: 21-04/281A

FIGURE 2-3
 APPROXIMATE EXTENT OF AFFECTED GROUND WATER FILL AREA
 FORMER GULF STATES CREOSOTING SITE
 HATTIESBURG, MISSISSIPPI

FILE COPY

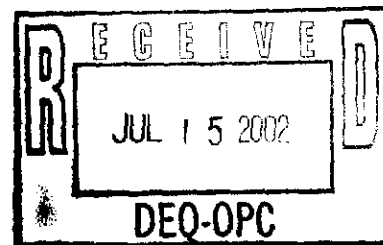
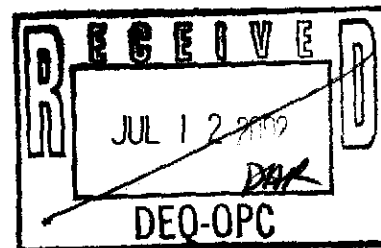

Revised
Remedial Action Work Plan
Former Gulf States Creosoting Site
Hattiesburg, Mississippi
July 12, 2002

July 12, 2002

Project No. 21-04

MICHAEL PISANI & ASSOCIATES, INC.
Environmental Management and Engineering Services
1100 Poydras Street
1430 Energy Centre
New Orleans, Louisiana 70163
(504) 582-2468

FILE COPY

**Table of Contents
Remedial Action Work Plan**

**Former Gulf States Creosoting Site
Hattiesburg, Mississippi**

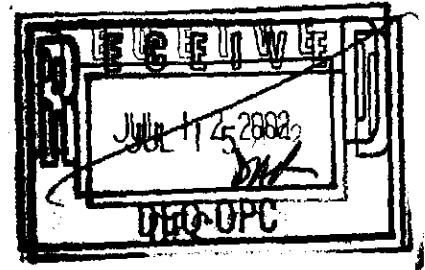

	Page
Executive Summary	1
1.0 Introduction	7
1.1 Site Background	7
1.2 Work Plan Objectives	7
1.3 General Plan	7
2.0 Summary of Remedial Investigation Findings	8
2.1 Site Environmental Setting	8
2.1.1 Topography and Surface Drainage	8
2.1.2 Site Geology	8
2.1.3 Ground Water Occurrence and Conditions	10
2.2 Nature and Extent of Affected Media	10
2.2.1 Fill Area	16
2.2.2 Former Process Area/Southern Railroad Track Area	28
3.0 Summary of Risk Assessment Findings	31
4.0 Selection of Remedial Alternatives	32
4.1 Fill Area	32
4.2 Former Process Area Subsurface Features	32
4.3 Southern Railroad Track Area	33
4.4 Northeast Drainage Ditch	33
5.0 Recommended Remedial Action	34
5.1 Fill Area	34
5.1.1 Culvert Installation	34
5.1.2 Sheet Piling Barrier	36
5.1.3 Gordon's Creek DNAPL Assessment	39
5.1.4 DNAPL Recovery and Monitoring System	41
5.1.5 Installation of Geosynthetic Clay Liner	41
5.1.6 Phytoremediation	44
5.1.7 Monitored Natural Attenuation	49

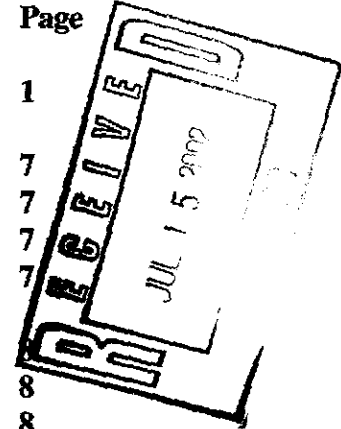

**Table of Contents
Remedial Action Work Plan**

FILE COPY

**Former Gulf States Creosoting Site
Hattiesburg, Mississippi**

	Page
5.2 Process Area Subsurface Features	49
5.2.1 Results of Limited Excavation Activities	50
5.2.2 Removal of Free Product and Creosote-Saturated Materials	50
5.2.3 Capping of Affected Soils	52
5.2.4 Monitored Natural Attenuation	52
5.3 Southern Railroad Track Area	52
5.3.1 Removal of Affected Soils	53
5.3.2 Capping of Affected Soils	53
5.3.3 Monitored Natural Attenuation	53
6.0 Contingency Plan	55

Appendices

A	Remedial Investigation Data Summary Tables
B	Feasibility Study
C	July 2001 Soil Boring Logs
D	Sealable Joint Sheet Piling Information
E	Contingency Plan

Table of Contents Remedial Action Work Plan

Former Gulf States Creosoting Site Hattiesburg, Mississippi

Figures

- 2-1 Site Drainage**
- 2-2 Cross-Section Location Map**
- 2-3 Former Process Area Cross-Sections**
- 2-4 Fill Area Cross-Sections**
- 2-5 Fill Area Potentiometric Surface Map – August 21-23, 2000**
- 2-6 Sand Channel Potentiometric Surface Map – August 21-23, 2000**
- 2-7 Benzo(a)pyrene Equivalence (mg/kg) in 0-2' Soil Samples**
- 2-8 Benzo(a)pyrene Equivalence (mg/kg) in 2-5' Soil Samples**
- 2-9 Benzo(a)pyrene Equivalence (mg/kg) in 5-10' Soil Samples**
- 2-10 Benzo(a)pyrene Equivalence (mg/kg) in 10-15' Soil Samples**
- 2-11 Benzo(a)pyrene Equivalence (mg/kg) in 15-20' Soil Samples**
- 2-12 Benzo(a)pyrene Equivalence in Soil Samples (mg/kg) – Offsite Process Area**
- 2-13 Naphthalene Concentrations in Ground Water Samples (ug/l) – Fill Area**
- 2-14 Naphthalene Concentrations in Ground Water Samples (ug/l) – Process Area and Offsite Ground Water**
- 2-15 Benzo(a)pyrene Equivalence/Total Non-Carcinogenic PAHs in Surface Water Samples (mg/l)**
- 2-16 Benzo(a)pyrene Equivalence in Sediment Samples (mg/kg)**
- 2-17 Approximate Extent of Affected Soil – Fill Area**
- 2-18 Approximate Extent of Affected Soil – Former Process Area**
- 5-1 ROST and Geoprobe Locations – Fill Area**
- 5-2 Configuration of Sheet Piling Barrier – Fill Area**
- 5-3 Sealable Sheet Pile Joint**
- 5-4 Sediment Coring Locations – Gordon's Creek**
- 5-5 DNAPL Recovery and Monitoring System Section View – Fill Area**
- 5-6 Recovery Well and Monitoring Well Locations – Fill Area**
- 5-7 Schematic Diagram of Proposed Tree Line**
- 5-8 Diagram of Tree Planting Areas – Fill Area**
- 5-9 Source Areas to be Remediated – Former Process Area**
- 5-10 Approximate Extent of Soil to be Removed and/or Capped – Southern Railroad Track Area**

Tables

- ES-1 Chronology of Site Response Activities**

Remedial Action Work Plan July 12, 2002

Former Gulf States Creosoting Site Hattiesburg, Mississippi

Executive Summary

Introduction

The Gulf States Creosoting site (the Site) is a former wood treating plant in Hattiesburg, Mississippi. Since 1996, Kerr-McGee Chemical (KMC) has conducted extensive investigations to determine the limits of affected media at the Site. Through the completion of this investigative process, referred to in both state and federal guidance as a Remedial Investigation (RI), the vertical extent and horizontal extent of affected media have been fully delineated.

In May 2001, KMC also completed a baseline risk assessment to evaluate existing and/or potential risks to human health and the environment. Both the RI and risk assessment have been approved by the Mississippi Department of Environmental Quality (MDEQ).

The results of the RI and risk assessment have been used to identify areas of the Site where remediation of affected media is necessary and appropriate. This work plan describes proposed remedial activities required to address affected media in these areas of potential concern.

Project Background

In January 1997, KMC, MDEQ, and the Mississippi Commission on Environmental Quality entered into an agreement for the investigation of the former Gulf States Creosoting site in Hattiesburg, Mississippi pursuant to MDEQ's Voluntary Evaluation Program (VEP). The agreement calls for characterization of the Site under the direction and review of the MDEQ Office of Pollution Control, Uncontrolled Sites Section. MDEQ guidance for the VEP states that investigations will include all activities necessary to characterize the environmental setting and to define the nature and extent of affected Site media. The MDEQ guidance refers to this investigative process as a Remedial Investigation.

A chronology of site response activities completed to date is provided in Table ES-1. The following reports presenting the results of site investigation activities have previously been submitted to MDEQ:

- *Remedial Investigation Report* (June 30, 1997)
- *Interim Report - Phase II Remedial Investigation*, August 14, 1998
- *Phase II Remedial Investigation Report* (December 30, 1998)
- *Report on Additional Site Investigation Activities* (November 22, 2000)
- *Report on Site Investigation Activities, February and March 2001* (June 12, 2001)
- Several letter reports presenting the results of additional subsurface soil sampling.

**Table ES-1
Chronology of Site Response Activities**

**Former Gulf States Creosoting Site
Hattiesburg, Mississippi**

<u>Date</u>	<u>Activity</u>
January 8, 1997	KMC submitted <i>Site Investigation Work Plan</i> to MDEQ
February 21, 1997	MDEQ approved <i>Site Investigation Work Plan</i> for implementation
April 30, 1997	KMC completed Phase I RI field activities
June 30, 1997	KMC submitted <i>Remedial Investigation Report</i>
January 13, 1998	MDEQ commented on <i>Remedial Investigation Report</i>
February 25, 1998	KMC submitted <i>Addendum to Site Investigation Work Plan</i>
March 16, 1998	KMC met with MDEQ to discuss proposed Phase II RI activities
April 8, 1998	KMC submitted <i>Revised Addendum to Site Investigation Work Plan</i>
April 23, 1998	MDEQ approved <i>Revised Addendum to Site Investigation Work Plan</i> for implementation
June 11, 1998	KMC completed the ground water screening portion of Phase II RI field activities
August 14, 1998	KMC submitted <i>Interim Report - Phase II Remedial Investigation</i>
August 26, 1998	MDEQ approved the monitoring well locations proposed in <i>Interim Report - Phase II Remedial Investigation</i>
October 14, 1998	KMC completed Phase II RI field activities
December 30, 1998	KMC submitted <i>Phase II Remedial Investigation Report</i>
April 20, 1999	MDEQ approved <i>Phase II Remedial Investigation Report</i>
April 20, 1999	KMC submitted <i>Proposed Work Plan for Developing Site-Specific, Risk-Based Cleanup Goals</i>
August 3, 1999	MDEQ approved <i>Proposed Work Plan for Developing Site-Specific, Risk-Based Cleanup Goals</i>

Table ES-1 (continued)
Chronology of Site Response Activities

Former Gulf States Creosoting Site
Hattiesburg, Mississippi

<u>Date</u>	<u>Activity</u>
November 12, 1999	KMC submitted <i>Human Health Risk Assessment</i>
January 14, 2000	KMC submitted <i>Ecological Risk Assessment</i>
February 14, 2000	KMC submitted <i>Remedial Action Work Plan</i>
June 21, 2000	KMC met with MDEQ to discuss areas where additional assessment activities warranted
July 25, 2000	MDEQ commented on <i>Ecological Risk Assessment</i>
August 2, 2000	MDEQ commented on <i>Human Health Risk Assessment</i>
August 3, 2000	KMC submitted <i>Work Plan for Additional Site Investigation Activities</i>
August 11, 2000	MDEQ approved <i>Work Plan for Additional Site Investigation Activities</i>
September 18, 2000	KMC completed additional site investigation field activities
November 2000	KMC submitted <i>Report on Additional Site Investigation Activities</i> and revised <i>Human Health Risk Assessment</i>
February 1, 2001	MDEQ commented on <i>Report on Additional Site Investigation Activities</i>
February 6, 2001	MDEQ commented on <i>Human Health Risk Assessment</i>
February 6, 2001	KMC submitted letter proposing additional site investigation activities
February 7, 2001	MDEQ approved proposed additional site investigation activities
March 2, 2001	KMC completed additional field activities
April 3, 2001	KMC submitted <i>Human Health Risk Assessment</i>

**Table ES-1 (continued)
Chronology of Investigation Activities**

**Former Gulf States Creosoting Site
Hattiesburg, Mississippi**

<u>Date</u>	<u>Activity</u>
April 20, 2001	MDEQ issued conditional approval of <i>Human Health Risk Assessment</i>
May 4, 2001	KMC submitted revised portions of <i>Human Health Risk Assessment</i>
May 4, 2001	MDEQ approved <i>Human Health Risk Assessment</i>
June 12, 2001	KMC submitted <i>Report on Additional Site Investigation Activities, February and March 2001</i>
June 20-21, 2001	KMC conducted limited excavation activities to delineate the extent of subsurface features in the former Process Area
June 25, 2001	KMC submitted <i>Ground Water Monitoring Plan</i>
July 10, 2001	MDEQ requested additional subsurface soil sampling across railroad tracks from former Process Area
July 17, 2001	MDEQ commented on February 14, 2000 <i>Remedial Action Work Plan</i> and <i>Ground Water Monitoring Plan</i>
July 19, 2001	KMC conducted additional subsurface soil sampling across railroad tracks from former Process Area
August 3, 2001	KMC submitted a <i>Removal Action Work Plan</i> for the northeast drainage ditch
September 4, 2001	KMC submitted a letter report presenting the results of additional subsurface soil sampling
September 19, 2001	KMC submitted a <i>Remedial Action Work Plan</i> for onsite areas
January 24, 2002	KMC conducted additional subsurface soil sampling in the vicinity of the former retort building
May 8, 2002	MDEQ commented on the August 3, 2001 <i>Removal Action Work Plan</i> and the September 19, 2001 <i>Remedial Action Work Plan</i>

In February 2000, KMC submitted to MDEQ a *Remedial Action Work Plan* for the Site. The work plan outlined proposed remedial activities to address affected media in the following areas:

- the Gordon's Creek Fill Area (the Fill Area);
- several subsurface features (i.e., storage tanks, a sump, and a suspected burial area) within the former Process Area;
- the area situated between the former Process Area and the Southern railroad tracks; and
- the northeast drainage ditch.

In a June 28, 2001 meeting, MDEQ and KMC agreed that in order to expedite cleanup of affected sediment and soil in the northeast drainage ditch, proposed activities to address the ditch would be presented in a stand-alone document. A *Removal Action Work Plan* for the northeast drainage ditch was submitted to MDEQ on August 3, 2001. Proposed response activities for affected media in the other above-listed areas, including additional work necessary to address MDEQ comments on the February 2000 plan, were presented in a *Remedial Action Work Plan* dated September 19, 2001.

Since the submittal of that plan, KMC and MDEQ have had numerous discussions and meetings regarding a mutually-acceptable remedy. On May 8, 2002, MDEQ provided written comments on the September 19, 2001 plan. This revised *Remedial Action Work Plan* incorporates KMC responses to MDEQ comments.

Overview of Proposed Remedial Action

Gordon's Creek Fill Area

The scope of remedial action for addressing the Fill Area consists of the following steps:

1. Install culvert in the ditch bisecting the Fill Area between West Pine Street and Gordon's Creek.
2. Drive sheet pilings to cut off intermittent seeps of dense non-aqueous phase liquids (DNAPLs) to Gordon's Creek.
3. Delineate the extent of visible DNAPLs in the Gordon's Creek streambed, and develop a plan to remediate DNAPLs, if necessary.
4. Install a recovery system behind the sheet piling barrier to collect, contain, and dispose of DNAPLs.
5. Install a geosynthetic clay liner atop affected Fill Area materials to inhibit the infiltration of precipitation through affected soils and reduce the potential for ground water mounding.
6. Implement a phytoremediation program to reduce the potential for ground water mounding, promote the capture of affected ground water, and accelerate further degradation of site constituents in shallow soils.

Process Area Subsurface Features

The scope of remedial action for addressing subsurface features within the former Process Area consists of the following steps:

1. Remove free product and creosote-saturated materials from within, beneath, and around a concrete sump. Transport the solids offsite for disposal at an acceptable location. Transport the liquids offsite for re-use or appropriate treatment/disposal.
2. Remove free product and creosote-saturated materials (i.e., soils and treated timbers) from a wooden substructure. Transport the materials offsite for disposal at an acceptable location.
3. Fill the excavations within the Process Area with clean fill materials. Cap the affected soils left in place with a water-impervious liner and asphalt to preclude direct contact and reduce the potential for infiltration of precipitation.

Southern Railroad Track Area

The scope of remedial action for addressing the area situated between the former Process Area and the Southern railroad tracks consists of the following steps:

1. Remove affected sediment and soils within and beneath drainage ditches. Transport the materials offsite for disposal at an acceptable location.
2. Either cap affected soils outside of the ditches with a water-impervious liner, drainage layer, and crushed rock or remove affected shallow soils (i.e., soils to a depth of 3 feet) then backfill and cap area to preclude infiltration of precipitation through affected soils (the final remedy is currently being negotiated with the railroad and MDEQ).

1.0 Introduction

Site background and general information on proposed response activities are provided in the following sections.

1.1 Site Background

The former Gulf States Creosoting site is located in Hattiesburg, Mississippi near the intersection of Scooba Street and West Pine Street. The Site is situated entirely within Section 16 of Township 4 North, Range 13 West in Forrest County, Mississippi, and is roughly bounded by the Southern railroad tracks to the southeast, Scooba Street to the northeast, Corinne Street and Gordon's Creek to the northwest, and U.S. Highway 49 to the southwest.

The wood treating facility operated between the early 1900s and approximately 1960. Operations at the facility were of a relatively small scale, consisting of the use of creosote only in a single pressure treating cylinder. The Site was redeveloped for commercial and light industrial use beginning in approximately 1962. There are no residential or institutional uses of the Site.

Results of the RI indicated that media affected by constituents of concern are present in four areas: 1) the Gordon's Creek Fill Area; 2) the former Process Area; 3) the Southern railroad track area; and 4) the northeast drainage ditch. RI findings are summarized in Section 2 of this document.

1.2 Work Plan Objectives

This work plan defines activities required to address affected media at the Site. The primary objectives of these response activities are to:

- mitigate intermittent releases of wood treating constituents to Gordon's Creek;
- address potential sources in the former Process Area; and
- reduce Site risks posed by potential exposure to affected surface soils.

1.3 General Plan

The general plan for remedial action at the Site has two primary components. The first component is the targeted cleanup of affected media in the Fill Area, the former Process Area, and the Southern Railroad track area. The second component is the use of institutional controls to ensure that: a) future uses of the affected areas of the Site are consistent with their current use (i.e., commercial and/or industrial); and b) current and future Site owners and/or lessees of the affected areas are advised of the presence of affected media and restrictions on land use.

2.0 Summary of Remedial Investigation Findings

Detailed results of Remedial Investigation (RI) activities were presented in the following reports:

- *Remedial Investigation Report* (June 30, 1997)
- *Interim Report - Phase II Remedial Investigation*, August 14, 1998
- *Phase II Remedial Investigation Report* (December 30, 1998)
- *Report on Additional Site Investigation Activities* (November 22, 2000)
- *Report on Site Investigation Activities, February and March 2001* (June 12, 2001)
- Letter report presenting the results of additional subsurface soil sampling (September 4, 2001).

A summary of the RI findings is provided in the following sections. Information on the site environmental setting is summarized in Section 2.1; information regarding the nature and extent of affected media is summarized in Section 2.2.

2.1 Site Environmental Setting

The following subsections contain information on the site topography and drainage, geology, and ground water occurrence and conditions.

2.1.1 Topography and Surface Drainage

Figure 2-1 is a topographic map of the Site prepared from a 1996 aerial survey by Atlantic Technologies of Huntsville, Alabama. The map indicates that present site elevations range from approximately 196 feet above mean sea level (msl) along a topographic ridge or divide in the north central portion of the Site to 176 feet msl within the Gordon's Creek channel at the western edge of the Site. The topographic divide for the Site is located approximately 300 to 400 feet southwest of Timothy Lane and runs roughly north-south. The ground surface west of this topographic divide slopes gradually from east to west, toward Gordon's Creek. East of the divide, the ground surface slopes northeastward toward Scooba Street.

Due to the presence of this topographic divide, surface drainage from the Site flows to two separate and distinct drainage basins. The first is a drainage basin created by a system of ditches and culverts, including the Southern railroad ditch immediately adjacent to Courtesy Ford, which flow eastward toward the Leaf River. The second is a drainage basin created by Gordon's Creek, which flows northward from the Site and eventually turns east towards the Leaf River. Surface runoff from the portion of the Site east of the topographic divide drains eastward toward the Leaf River via the ditch and culvert system; the remainder of the Site drains westward toward Gordon's Creek. Current site drainage is depicted on Figure 2-1.

2.1.2 Site Geology

Results of RI activities show the shallow geology of the former Process Area and Fill Area to be significantly different, with the exception of an underlying hard clay aquitard common to both areas. The top of this hard clay aquitard was encountered in all borings at elevations

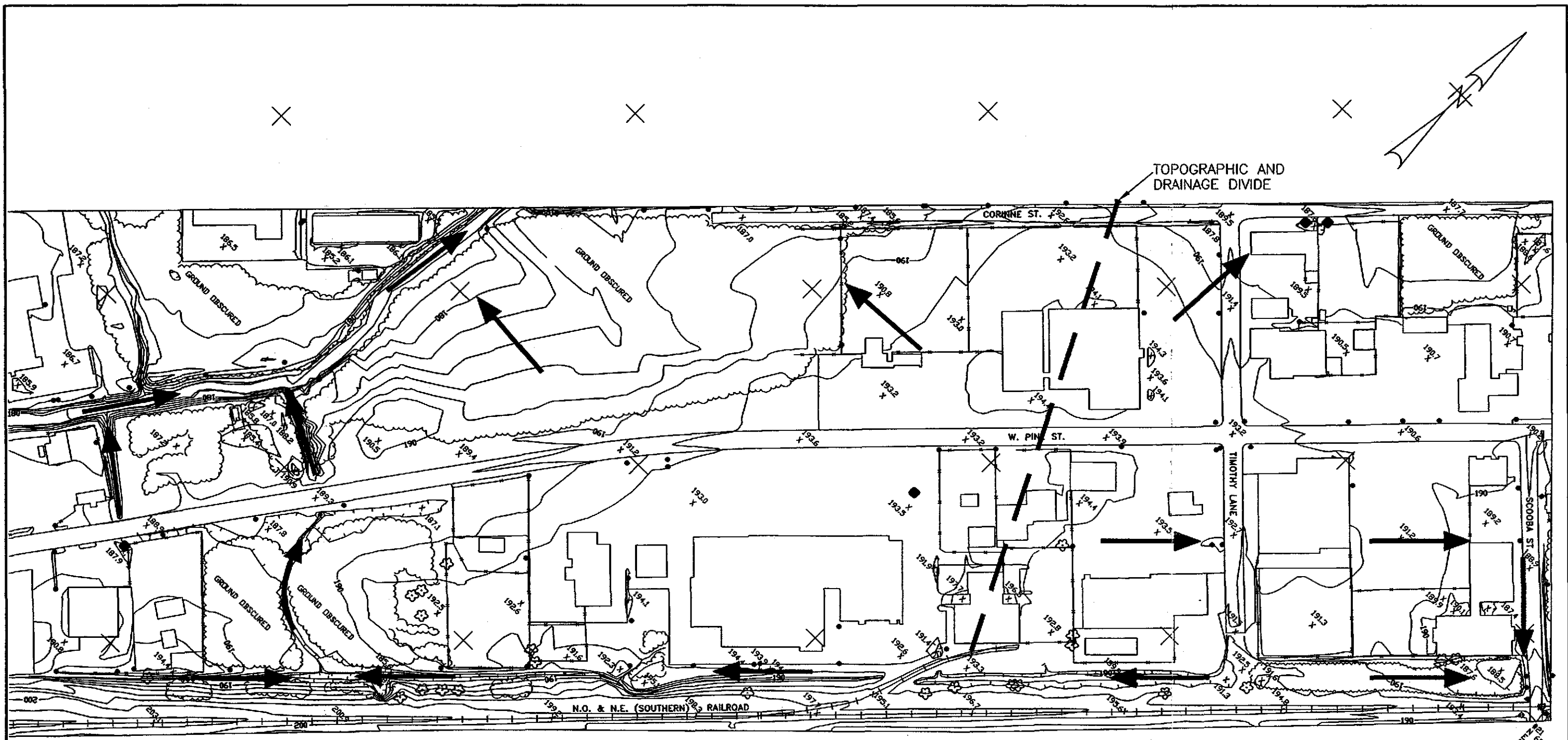

LEGEND

 GENERAL DIRECTION OF SURFACE DRAINAGE

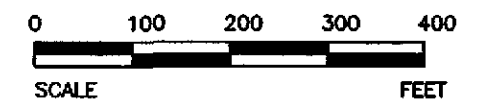

BASE MAP FROM ATLANTIC TECHNOLOGIES, LTD., HUNTSVILLE, ALABAMA, APRIL 1, 1996

MICHAEL PISANI & ASSOCIATES
Environmental Management and Engineering Services
New Orleans, Louisiana Houston, Texas

TITLE:	FIGURE 2-1 SITE DRAINAGE	
PROJECT:	FORMER GULF STATES CREOSOTING SITE	
LOCATION:	HATTIESBURG, MISSISSIPPI	
SCALE:	1"=200'	DWG. NO.: 21-04/70B

ranging from 145 to 165 feet above mean sea level (amsl). Published reports and geologic logs from wells in the Hattiesburg area indicate that this is roughly equivalent in elevation to the top of the massive Hattiesburg clay. No borings advanced during the RI fully penetrated the clay layer, which is reportedly between 120 and 200 feet thick in the Hattiesburg area.

The former Process Area geology is characterized by the presence of an upper clay unit, a sand channel, and the underlying Hattiesburg clay aquitard. The thickness of the upper clay unit ranges from 20 to 25 feet beneath the former Process Area, while the maximum thickness of the sand channel is 21 feet. The sand channel, which is the uppermost water-bearing zone beneath the former Process Area, pinches out to the west and does not extend westward to Gordon's Creek or beneath the Fill Area.

The Fill Area geology is characterized by shallow interbedded sands and clays underlain by the Hattiesburg clay aquitard. The interbedded sand deposits, which comprise the uppermost water-bearing zone beneath the Fill Area, do not extend eastward to the former Process Area. The shallow water-bearing zones beneath the former Process Area and Fill Area are not interconnected.

The locations of cross-sections depicting the geology of the former Process Area and Fill Area are shown on Figure 2-2. Cross-sections through the former Process Area and the Fill Area are displayed on Figures 2-3 and 2-4, respectively.

2.1.3 Ground Water Occurrence and Conditions

Just as the shallow geology of the former Process Area and Fill Area are significantly different, the shallow aquifer systems beneath the two areas are separate and distinct. As stated above, the uppermost water-bearing zone beneath the former Process Area does not extend westward to the Fill Area, and the uppermost water-bearing zones beneath the Fill Area do not extend eastward to the former Process Area. Furthermore, ground water within the two zones flows in completely opposite directions. Ground water within the Fill Area sands flows westward toward Gordon's Creek and downstream along the creek (see Figure 2-5). Ground water within the former Process Area sand channel flows eastward toward the Leaf River (see Figure 2-6).

2.2 Nature and Extent of Affected Media

The discussion regarding nature and extent of affected media at the Site is broken down into the following sections of this report:

2.2.1 Fill Area (DNAPL, soil, ground water,)

2.2.2 Former Process Area/Southern Railroad Track Area (free product, soil, ground water)

During the Phase I RI, a Rapid Optical Screening Tool (ROST) was used to determine the nature and extent of affected soil within the former Process Area and the Fill Area. The ROST system combines cone penetrometer testing (CPT) and laser-induced fluorescence

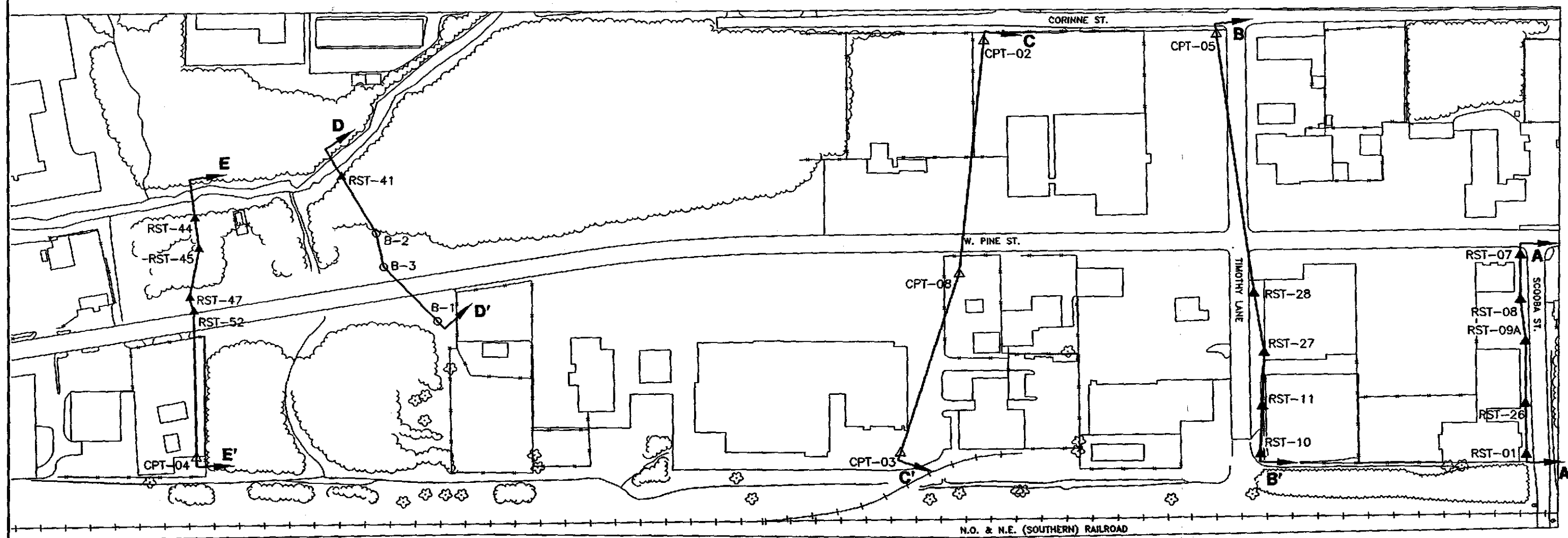
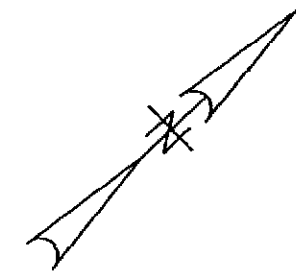

LEGEND

- △ CPT PUSH
- ▲ ROST PUSH
- SOIL BORING

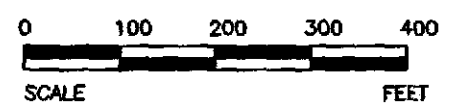

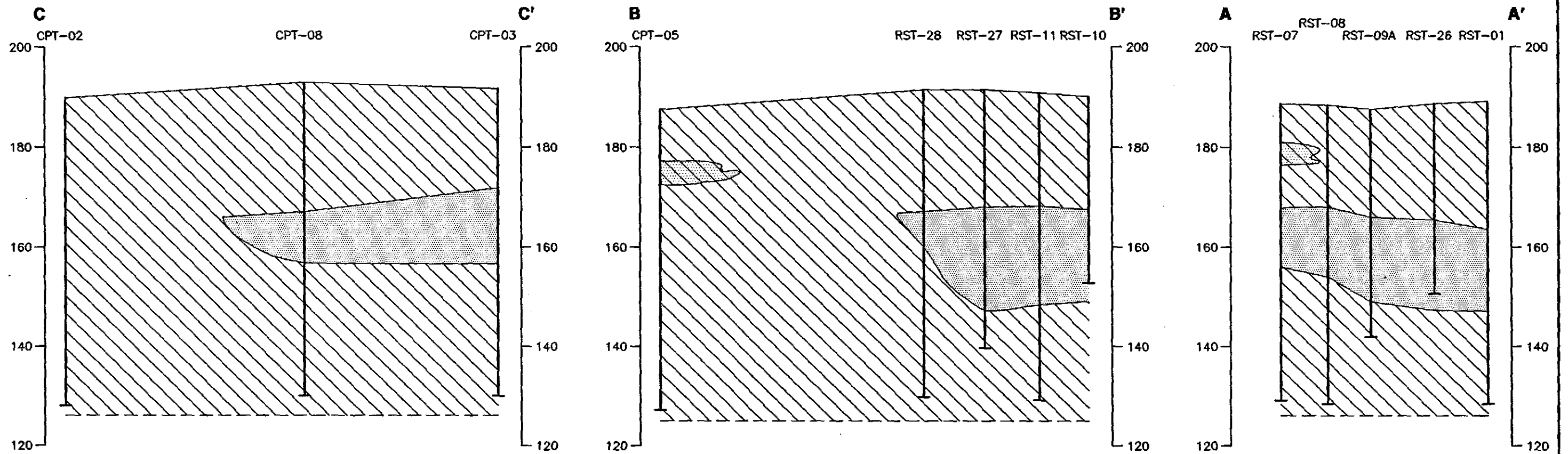

BASE MAP FROM ATLANTIC TECHNOLOGIES, LTD.,
HUNTSVILLE, ALABAMA, APRIL 1, 1996

MICHAEL PISANI & ASSOCIATES Environmental Management and Engineering Services New Orleans, Louisiana Houston, Texas	
TITLE: FIGURE 2-2 CROSS-SECTION LOCATION MAP	
PROJECT: FORMER GULF STATES CREOSOTING SITE	
LOCATION: HATTIESBURG, MISSISSIPPI	
SCALE: 1"=200'	DWG. NO.: 21-04/71B



LEGEND

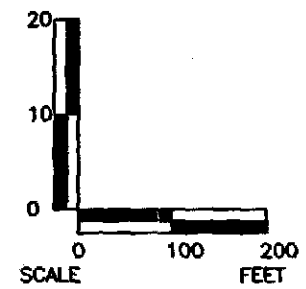

-  SAND CHANNEL
-  SANDY CLAY/CLAYEY SAND
-  CLAY

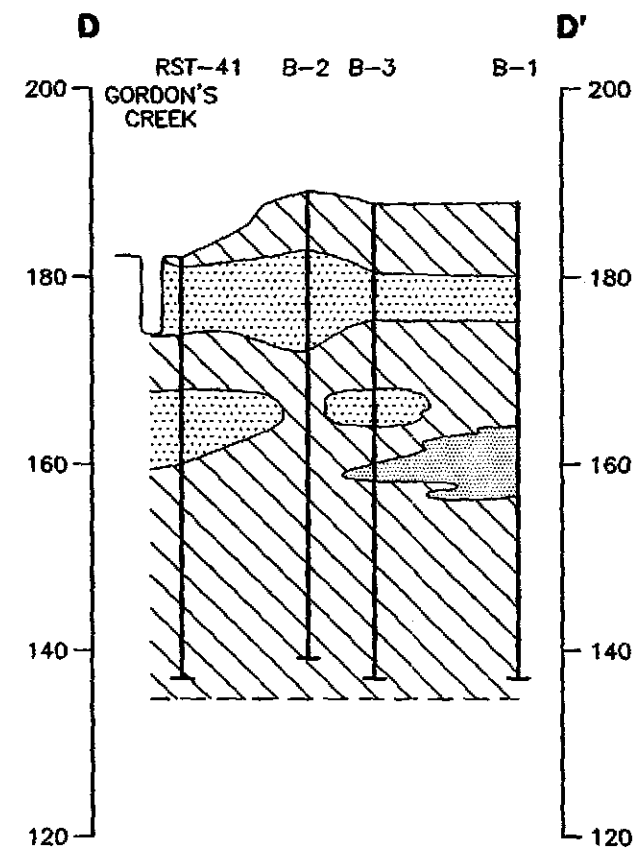
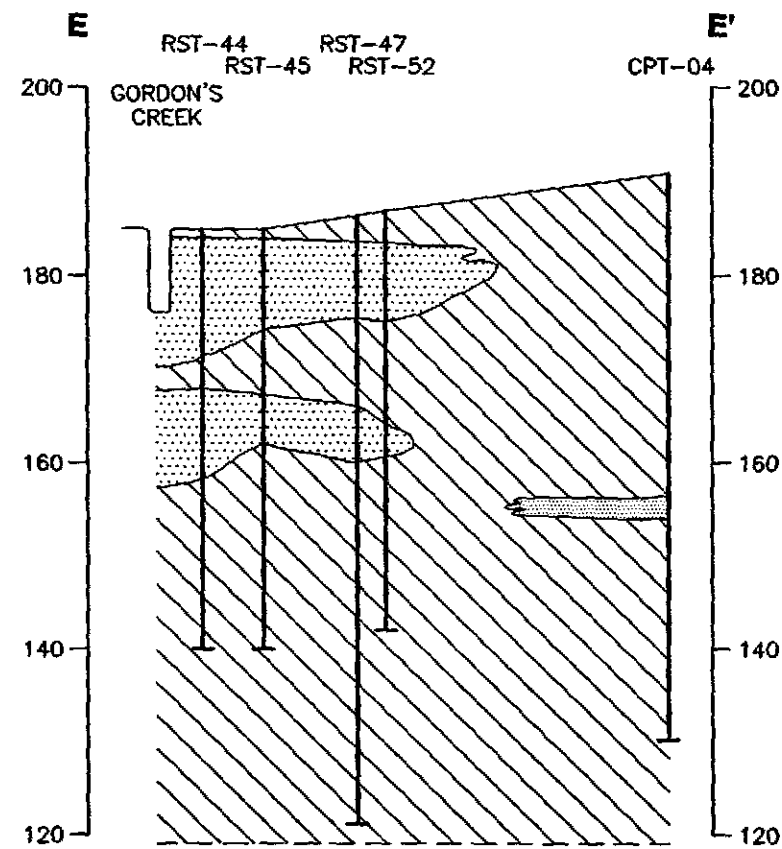

MICHAEL PISANI & ASSOCIATES	
Environmental Management and Engineering Services	
New Orleans, Louisiana	Houston, Texas
TITLE: FIGURE 2-3 FORMER PROCESS AREA CROSS-SECTIONS	
PROJECT: FORMER GULF STATES CREOSOTING SITE	
LOCATION: HATTIESBURG, MISSISSIPPI	
SCALE: 1"=200'/1"=20'	DWG. NO.: 21-04/72B



LEGEND

-  SAND CHANNEL
-  GORDON'S CREEK SAND DEPOSITS
-  CLAY

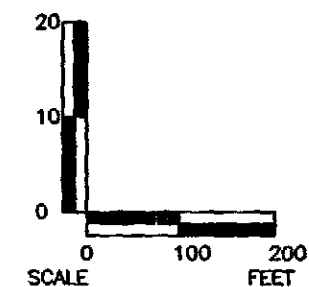

MICHAEL PISANI & ASSOCIATES	
Environmental Management and Engineering Services	
New Orleans, Louisiana	Houston, Texas
TITLE: FIGURE 2-4 FILL AREA CROSS-SECTIONS	
PROJECT: FORMER GULF STATES CREOSOTING SITE	
LOCATION: HATTIESBURG, MISSISSIPPI	
SCALE: 1"=200' / 1"=20'	DWG. NO.: 21-04/73B

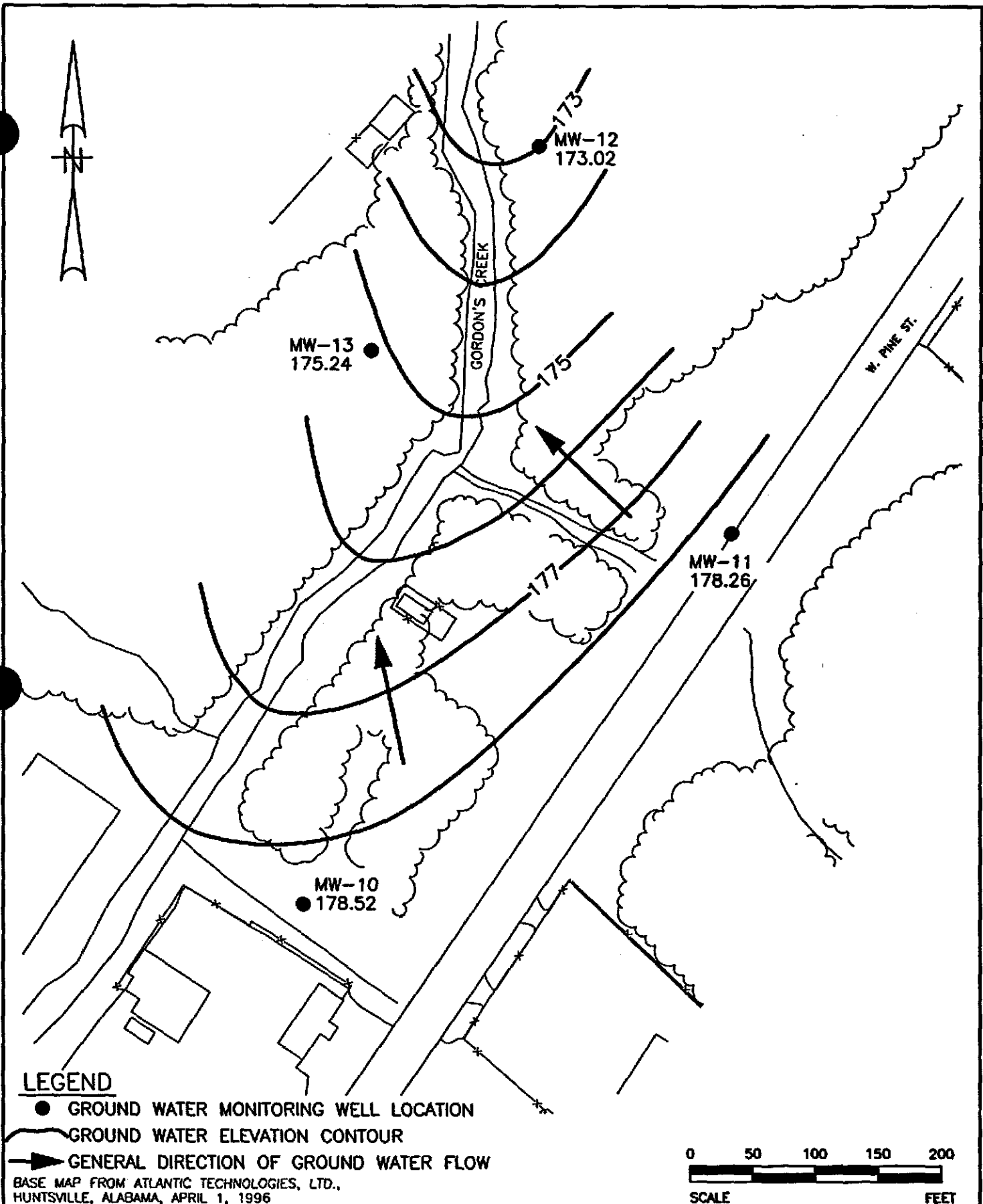

LEGEND

- GROUND WATER MONITORING WELL LOCATION
- GROUND WATER ELEVATION CONTOUR
- ➔ GENERAL DIRECTION OF GROUND WATER FLOW

BASE MAP FROM ATLANTIC TECHNOLOGIES, LTD.,
HUNTSVILLE, ALABAMA, APRIL 1, 1996

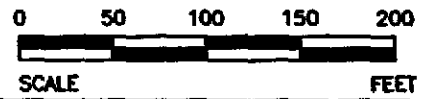

MICHAEL PISANI & ASSOCIATES
Environmental Management and Engineering Services
New Orleans, Louisiana Houston, Texas

FIGURE 2-5
FILL AREA
POTENTIOMETRIC SURFACE MAP - AUGUST 21-23, 2000
FORMER GULF STATES CREOSOTING SITE
HATTIESBURG, MISSISSIPPI

SCALE: 1"=100'

DWG. NO.: 21-04/224A

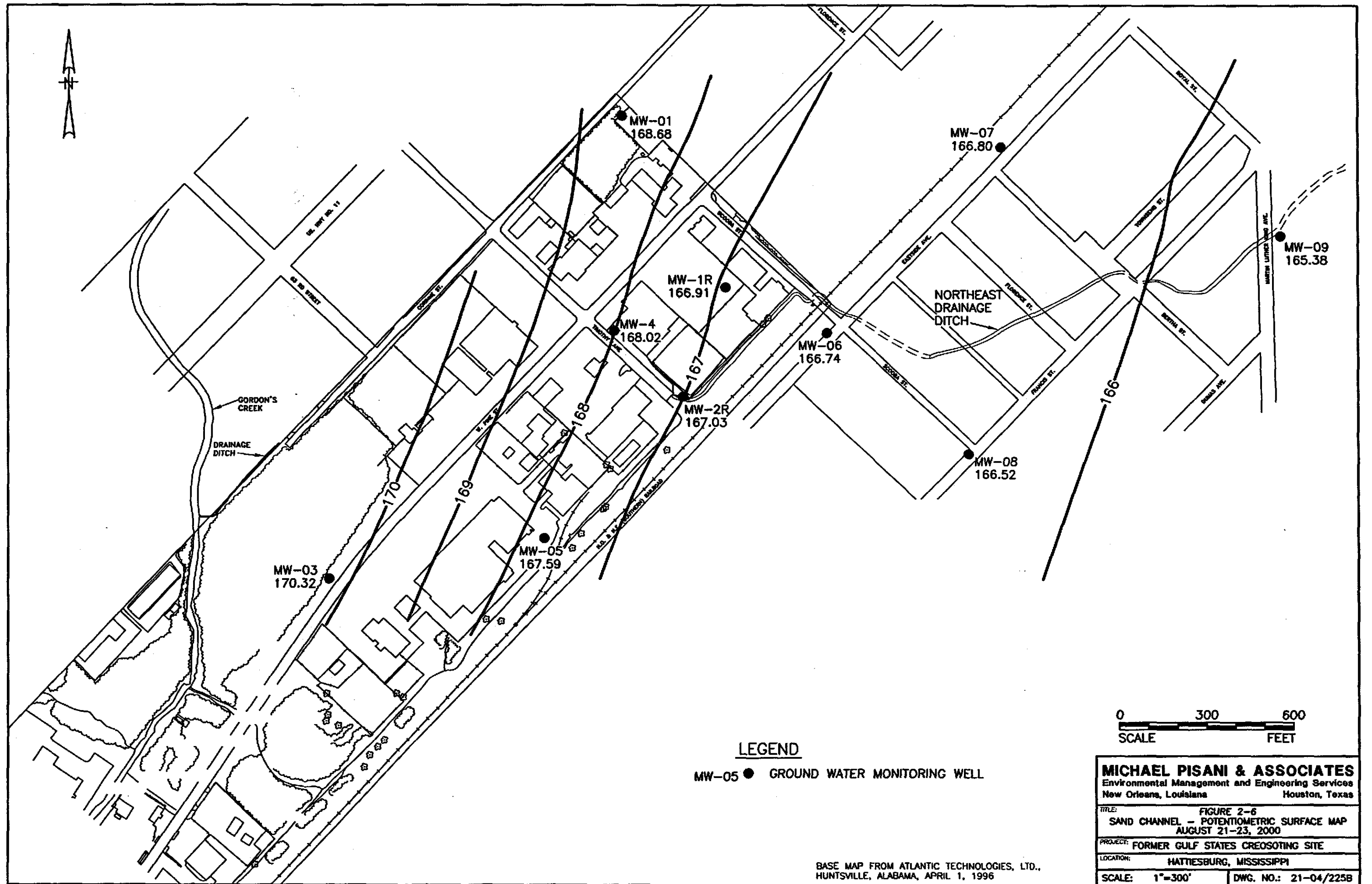

LEGEND

MW-05 ● GROUND WATER MONITORING WELL



MICHAEL PISANI & ASSOCIATES	
Environmental Management and Engineering Services	
New Orleans, Louisiana	Houston, Texas
TITLE: FIGURE 2-6	
SAND CHANNEL - POTENTIOMETRIC SURFACE MAP	
AUGUST 21-23, 2000	
PROJECT: FORMER GULF STATES CREOSOTING SITE	
LOCATION: HATTIESBURG, MISSISSIPPI	
SCALE: 1"=300'	DWG. NO.: 21-04/225B

BASE MAP FROM ATLANTIC TECHNOLOGIES, LTD., HUNTSVILLE, ALABAMA, APRIL 1, 1996

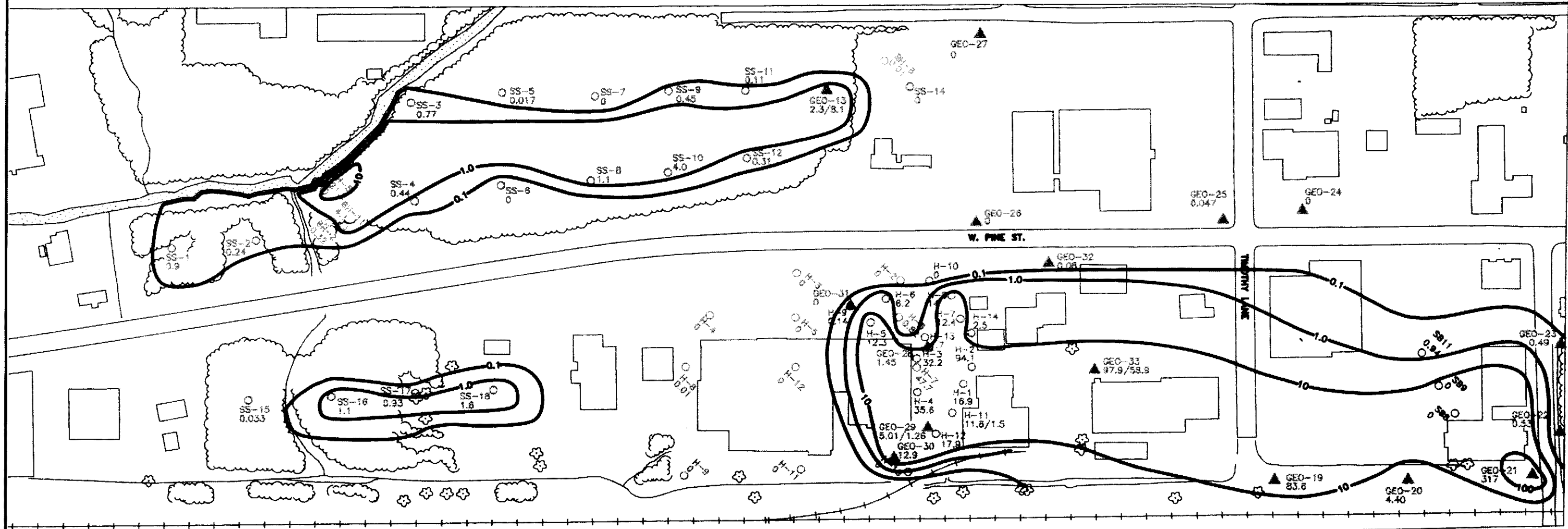
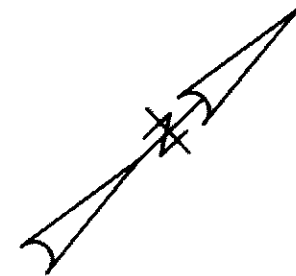

SITE INSPECTION,
1/82 BY MDEE FOR EPA

SOIL GAS AND SOIL SAMPLING,
5/90 BY ROY F. WESTON FOR EPA

PHASE II INVESTIGATION OF PROCESS
AREA, 1994 BY EPS FOR VAN SLYKE

PHASE II INVESTIGATION OF GIBSON'S
SHOPPING CENTER, 8/94 BY BONNER
FOR MS. THOMAS

PRELIMINARY SUBSURFACE INVESTIGATION OF
RYAN MOTORS/RSCC REALTY, 10/94 BY
BONNER ANALYTICAL TESTING

ADDITIONAL INVESTIGATION OF GIBSON'S
SHOPPING CENTER, 7/95 BY BONNER
FOR MS. THOMAS

REPORT ON INVESTIGATION ACTIVITIES
8/96 BY MELAREN HART FOR VAN SLYKE

SOIL BORING ASSESSMENT,
6/96 BY TDS

REMEDIAL INVESTIGATION, BY MP&A
FOR KMCC

LEGEND

- SS-7 ○ HISTORICAL SOIL BORING/SAMPLE
- GEO-26 ▲ PHASE II SOIL BORING/SAMPLE
- 0.1— BENZO(A)PYRENE ISOCONCENTRATION LINE (mg/kg)

NOTE:
CONTOUR LINES BETWEEN KNOWN POINTS
ARE INTERPOLATIONS AND MAY NOT ACCURATELY
REPRESENT CONSTITUENT CONCENTRATIONS.



*Text page 16
missing in
this report*
*TR
8/2/00*

MICHAEL PISANI & ASSOCIATES
Environmental Management and Engineering Services
New Orleans, Louisiana Houston, Texas

TITLE:	FIGURE 2-7 BENZO(A)PYRENE EQUIVALENCE (mg/kg) IN 0-2" SOIL SAMPLES	
PROJECT:	FORMER GULF STATES CREOSOTING SITE	
LOCATION:	HATTIESBURG, MISSISSIPPI	
SCALE:	1"=200'	DWG. NO.: 21-04/788

BASE MAP FROM ATLANTIC TECHNOLOGIES, LTD.,
HUNTSVILLE, ALABAMA, APRIL 1, 1996

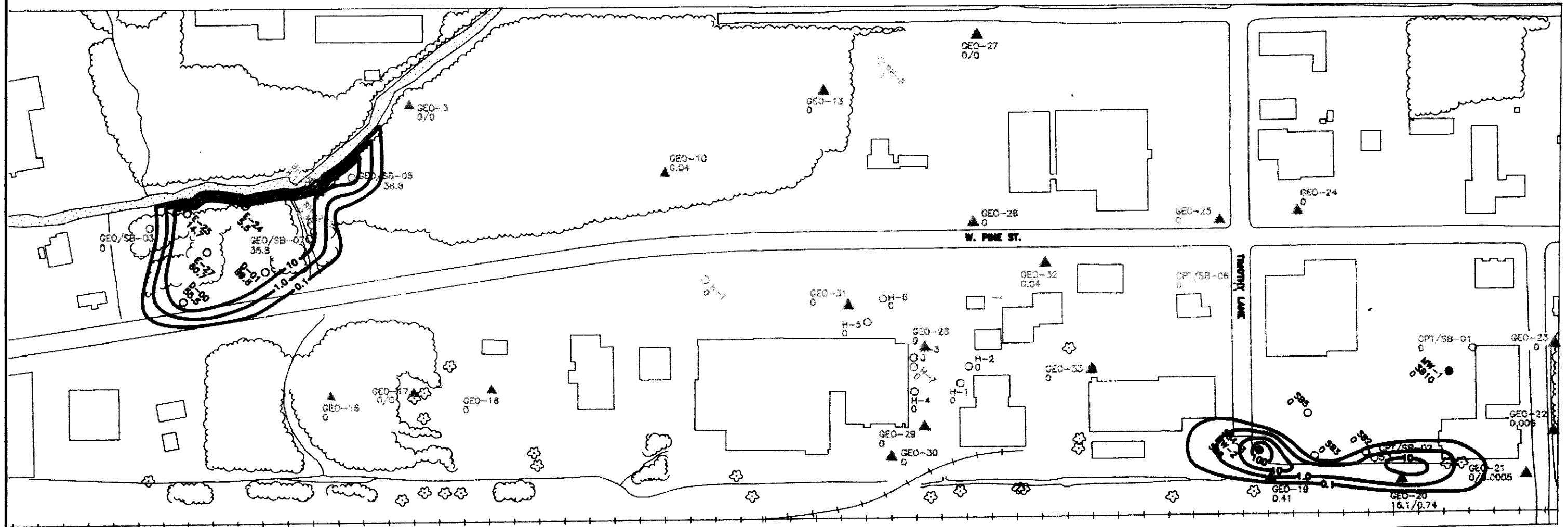
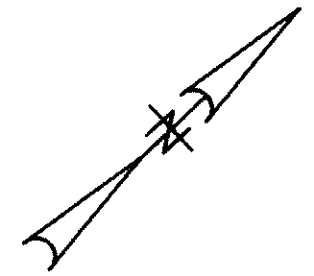

SITE INSPECTION,
1/92 BY MBEQ FOR EPA

SOIL GAS AND SOIL SAMPLING,
5/90 BY ROY F. WESTON FOR EPA

PHASE II INVESTIGATION OF PROCESS
AREA, 1994 BY EPS FOR VAN SLYKE

PHASE II INVESTIGATION OF GIBSON'S
SHOPPING CENTER, 6/94 BY BONNER
FOR MS. THOMAS

PRELIMINARY SUBSURFACE INVESTIGATION OF
RYAN MOTORS/BSCO REALTY, 10/94 BY
BONNER ANALYTICAL TESTING

ADDITIONAL INVESTIGATION OF GIBSON'S
SHOPPING CENTER, 7/95 BY BONNER
FOR MS. THOMAS

REPORT OF INVESTIGATION ACTIVITIES
6/96 BY MELAREN HART FOR VAN SLYKE

SOIL BORING ASSESSMENT,
6/96 BY TDS

REMEDIAL INVESTIGATION, BY MP&A
FOR KMCC

LEGEND

- SBS ○ HISTORICAL SOIL BORING/SAMPLE
- GEO-26 ▲ PHASE II RI SOIL BORING/SAMPLE
- MW-1 ● HISTORICAL MONITOR WELL
- 0.1— BENZO(a)PYRENE ISOCONCENTRATION LINE (mg/kg)

NOTE:
CONTOUR LINES BETWEEN KNOWN POINTS
ARE INTERPOLATIONS AND MAY NOT ACCURATELY
REPRESENT CONSTITUENT CONCENTRATIONS.



MICHAEL PISANI & ASSOCIATES
Environmental Management and Engineering Services
New Orleans, Louisiana Houston, Texas

TITLE: **FIGURE 2-9
BENZO(A)PYRENE EQUIVALENCE (mg/kg)
IN 5-10' SOIL SAMPLES**

PROJECT: FORMER GULF STATES CREOSOTING SITE

LOCATION: HATTIESBURG, MISSISSIPPI

SCALE: 1"=200' DWG. NO.: 21-04/788

BASE MAP FROM ATLANTIC TECHNOLOGIES, LTD.,
HUNTSVILLE, ALABAMA, APRIL 1, 1996

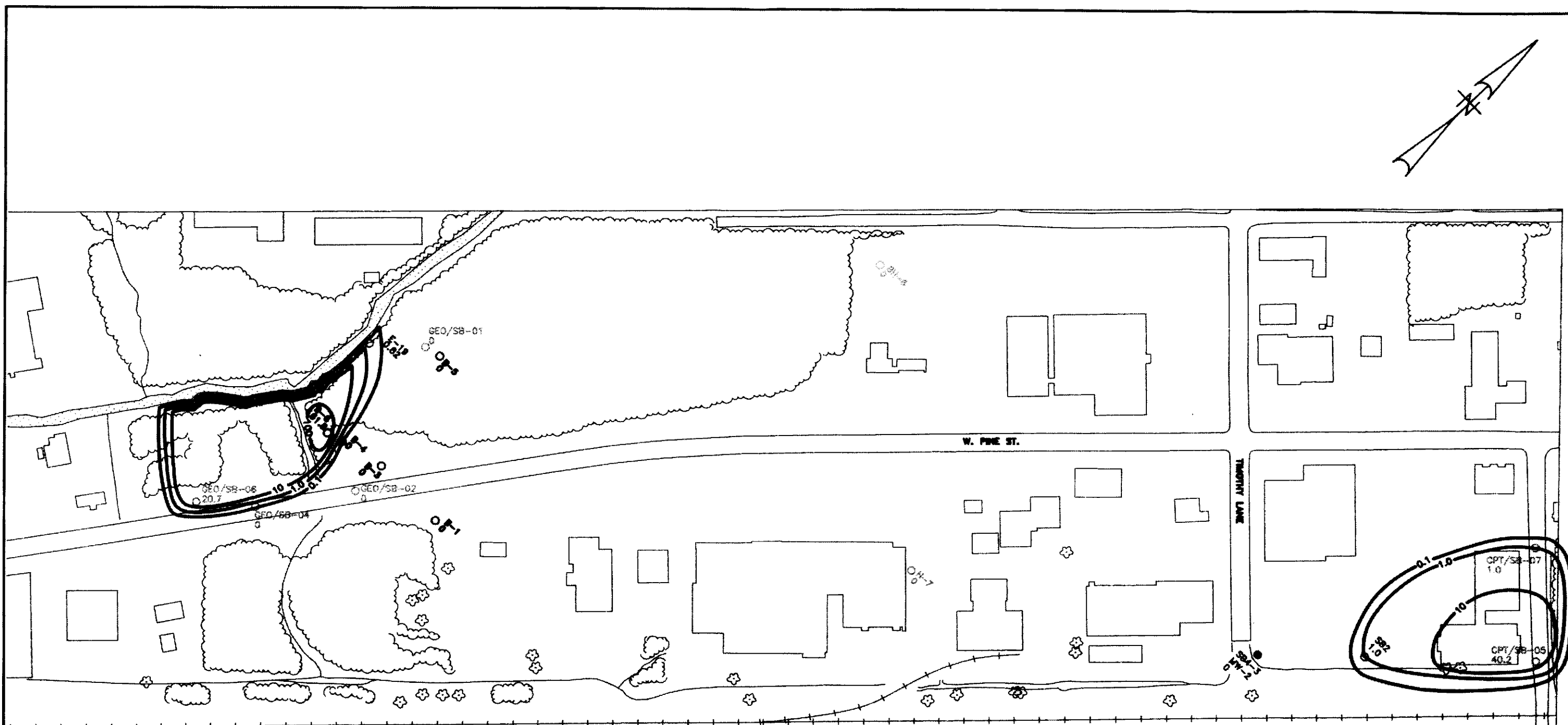
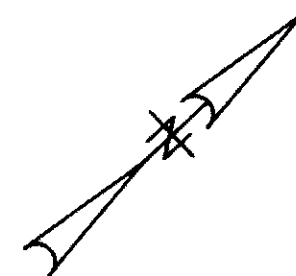

**SITE INSPECTION,
1/82 BY NDEG FOR EPA**

**SOIL GAS AND SOIL SAMPLING,
5/90 BY ROY F. WESTON FOR EPA**

**PHASE II INVESTIGATION OF PROCESS
AREA, 1994 BY EPS FOR VAN SLYKE**

**PHASE II INVESTIGATION OF GIBSON'S
SHOPPING CENTER, 8/94 BY BONNER
FOR MS. THOMAS**

**PRELIMINARY SUBSURFACE INVESTIGATION OF
RYAN MOTORS/RSCC REALTY, 10/94 BY
BONNER ANALYTICAL TESTING**

**ADDITIONAL INVESTIGATION OF GIBSON'S
SHOPPING CENTER, 7/95 BY BONNER
FOR MS. THOMAS**

**REPORT OF INVESTIGATION ACTIVITIES
6/98 BY DELANEY HART FOR VAN SLYKE**

**SOIL BORING ASSESSMENT,
6/98 BY TDS**

**REMEDIAL INVESTIGATION, 1997 BY MP&A
FOR KMCC**

LEGEND

- 1 HISTORICAL SOIL BORING/SAMPLE
- HISTORICAL MONITOR WELL
- 0.1— BENZO(a)PYRENE ISOCENTRATION LINE (mg/kg)

NOTE:
CONTOUR LINES BETWEEN KNOWN POINTS
ARE INTERPOLATIONS AND MAY NOT ACCURATELY
REPRESENT CONSTITUENT CONCENTRATIONS.



MICHAEL PISANI & ASSOCIATES
Environmental Management and Engineering Services
New Orleans, Louisiana Houston, Texas

TITLE: FIGURE 2-10 BENZO(A)PYRENE EQUIVALENCE (mg/kg) IN 10-15' SOIL SAMPLES	
PROJECT: FORMER GULF STATES CREOSOTING SITE	
LOCATION: HATTIESBURG, MISSISSIPPI	
SCALE: 1"=200'	DWG. NO.: 21-04/798

BASE MAP FROM ATLANTIC TECHNOLOGIES, LTD.,
HUNTSVILLE, ALABAMA, APRIL 1, 1996

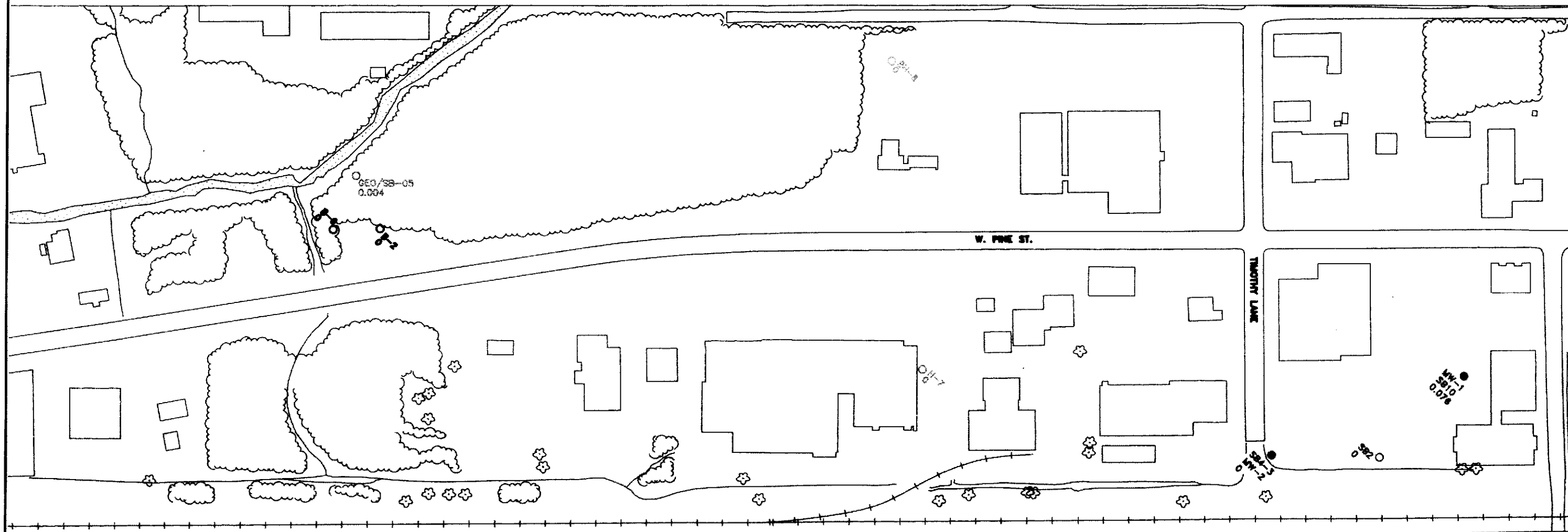
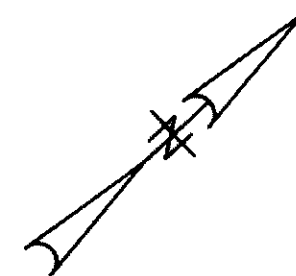

**SITE INSPECTION,
1/92 BY MDEQ FOR EPA**

**SOIL GAS AND SOIL SAMPLING,
5/90 BY ROY F. WESTON FOR EPA**

**PHASE II INVESTIGATION OF PROCESS
AREA, 1994 BY EPS FOR VAN SLYKE**

**PHASE II INVESTIGATION OF GIBSON'S
SHOPPING CENTER, 8/94 BY BONNER
FOR MS. THOMAS**

**PRELIMINARY SUBSURFACE INVESTIGATION OF
RYAN MOTORS/RSCD REALTY, 10/94 BY
BONNER ANALYTICAL TESTING**

**ADDITIONAL INVESTIGATION OF GIBSON'S
SHOPPING CENTER, 7/95 BY BONNER
FOR MS. THOMAS**

**REPORT OF INVESTIGATION ACTIVITIES
8/95 BY WESTON PART FOR VAN SLYKE**

**SOIL BORING ASSESSMENT,
8/96 BY TDS**

**REMEDIAL INVESTIGATION, 1997 BY NP&A
FOR KMCC**

LEGEND

- HISTORICAL SOIL BORING/SAMPLE
- HISTORICAL MONITOR WELL



MICHAEL PISANI & ASSOCIATES
Environmental Management and Engineering Services
New Orleans, Louisiana Houston, Texas

**TITLE: FIGURE 2-11
 BENZO(A)PYRENE EQUIVALENCE (mg/kg)
 IN 15-20' SOIL SAMPLES**

PROJECT: FORMER GULF STATES CREOSOTING SITE

LOCATION: HATTIESBURG, MISSISSIPPI

SCALE: 1"=200' DWG. NO.: 21-04/808

**BASE MAP FROM ATLANTIC TECHNOLOGIES, LTD.,
HUNTSVILLE, ALABAMA, APRIL 1, 1996**

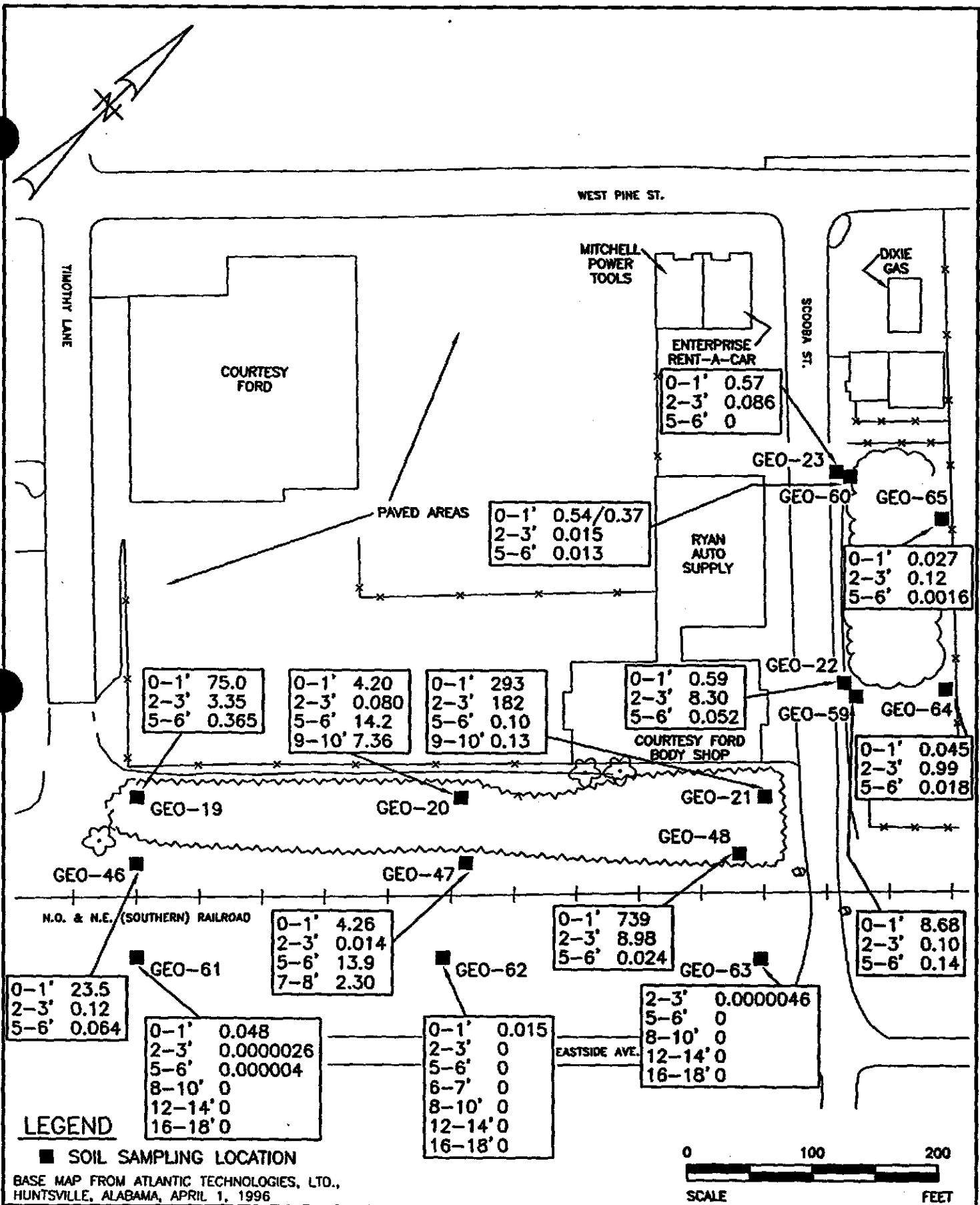

MICHAEL PISANI & ASSOCIATES
 Environmental Management and Engineering Services
 New Orleans, Louisiana Houston, Texas

SCALE: 1"=100' DWG. NO.: 21-04/226A

FIGURE 2-12
 BENZO(a)PYRENE EQUIVALENCE IN SOIL SAMPLES (mg/kg)
 OFFSITE PROCESS AREA
 FORMER GULF STATES CREOSOTING SITE
 HATTIESBURG, MISSISSIPPI

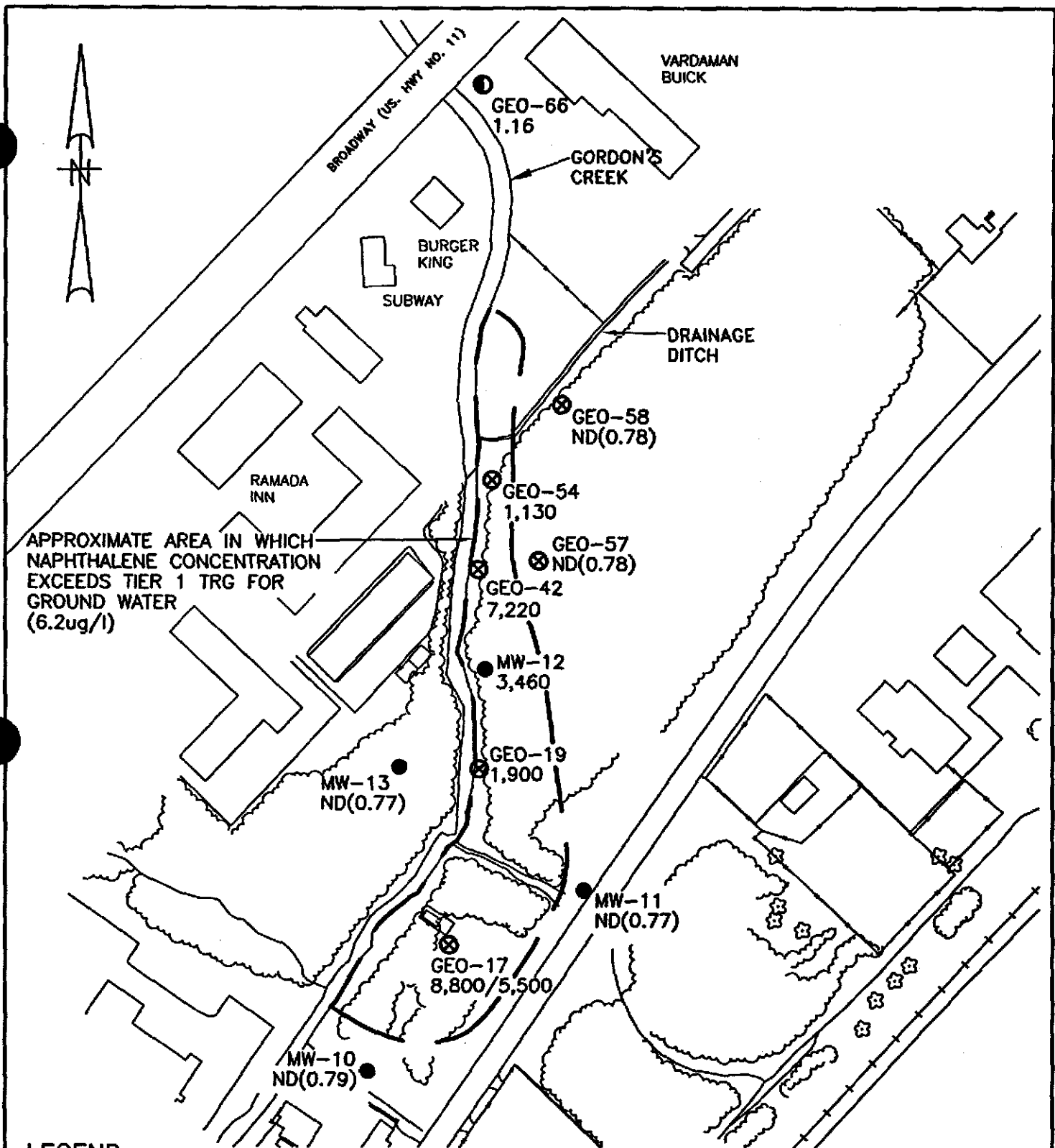

LEGEND

- MONITORING WELL
- ① 2001 GROUND WATER SCREENING LOCATION
- ⊗ PREVIOUS GROUND WATER SCREENING LOCATION

BASE MAP FROM ATLANTIC TECHNOLOGIES, LTD., HUNTSVILLE, ALABAMA, APRIL 1, 1996



MICHAEL PISANI & ASSOCIATES
Environmental Management and Engineering Services
New Orleans, Louisiana Houston, Texas

FIGURE 2-13
NAPHTHALENE CONCENTRATIONS IN GROUND WATER (ug/l)
FILL AREA

FORMER GULF STATES CREOSOTING SITE
HATTIESBURG, MISSISSIPPI

SCALE: 1"=200'

DWG. NO.: 21-04/227A

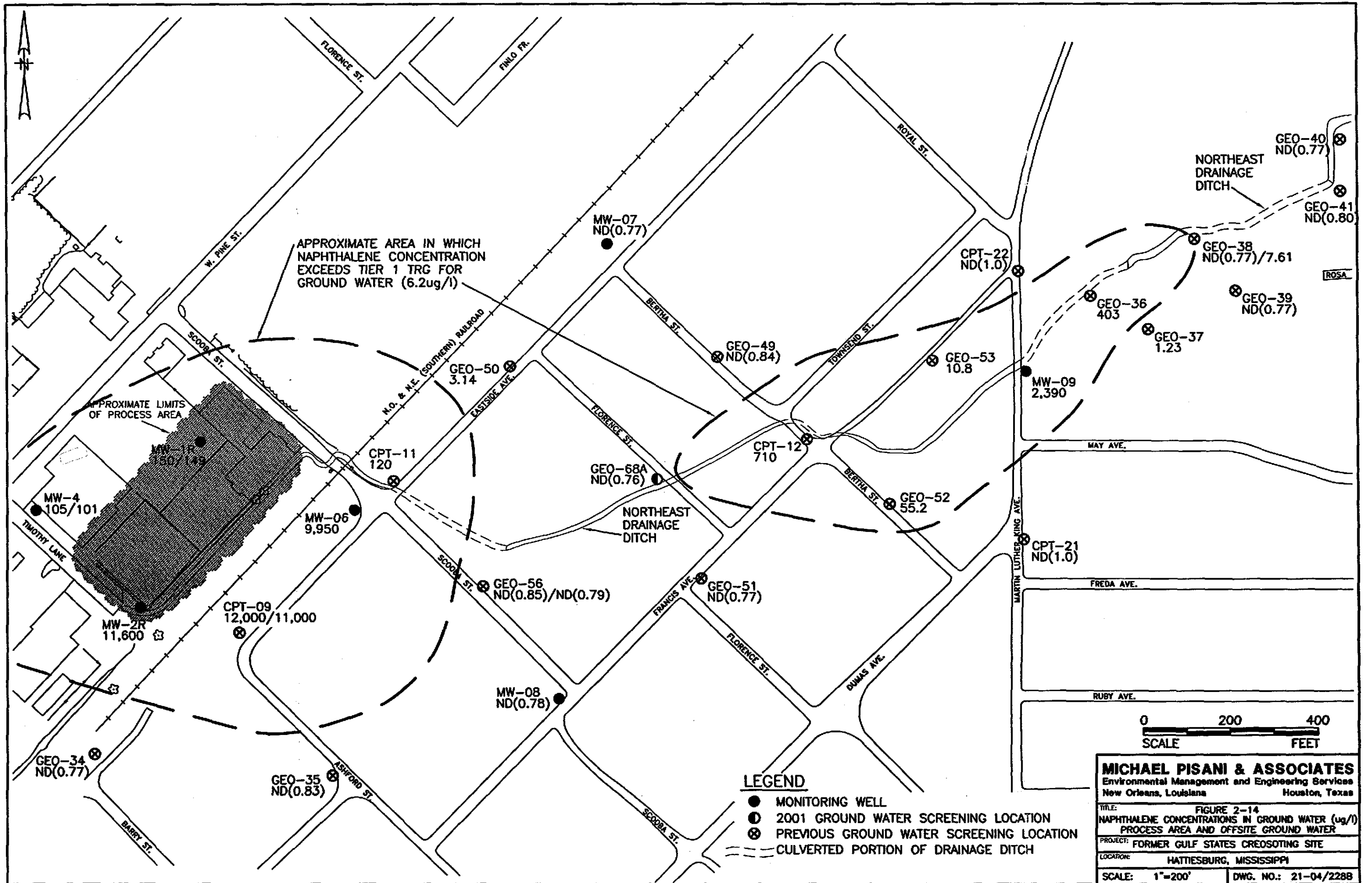

- LEGEND**
- MONITORING WELL
 - ① 2001 GROUND WATER SCREENING LOCATION
 - ⊗ PREVIOUS GROUND WATER SCREENING LOCATION
 - CULVERTED PORTION OF DRAINAGE DITCH

MICHAEL PISANI & ASSOCIATES
Environmental Management and Engineering Services
New Orleans, Louisiana Houston, Texas

TITLE: FIGURE 2-14
NAPHTHALENE CONCENTRATIONS IN GROUND WATER (ug/l)
PROCESS AREA AND OFFSITE GROUND WATER

PROJECT: FORMER GULF STATES CREOSOTING SITE

LOCATION: HATTIESBURG, MISSISSIPPI

SCALE: 1"=200' DWG. NO.: 21-04/2288

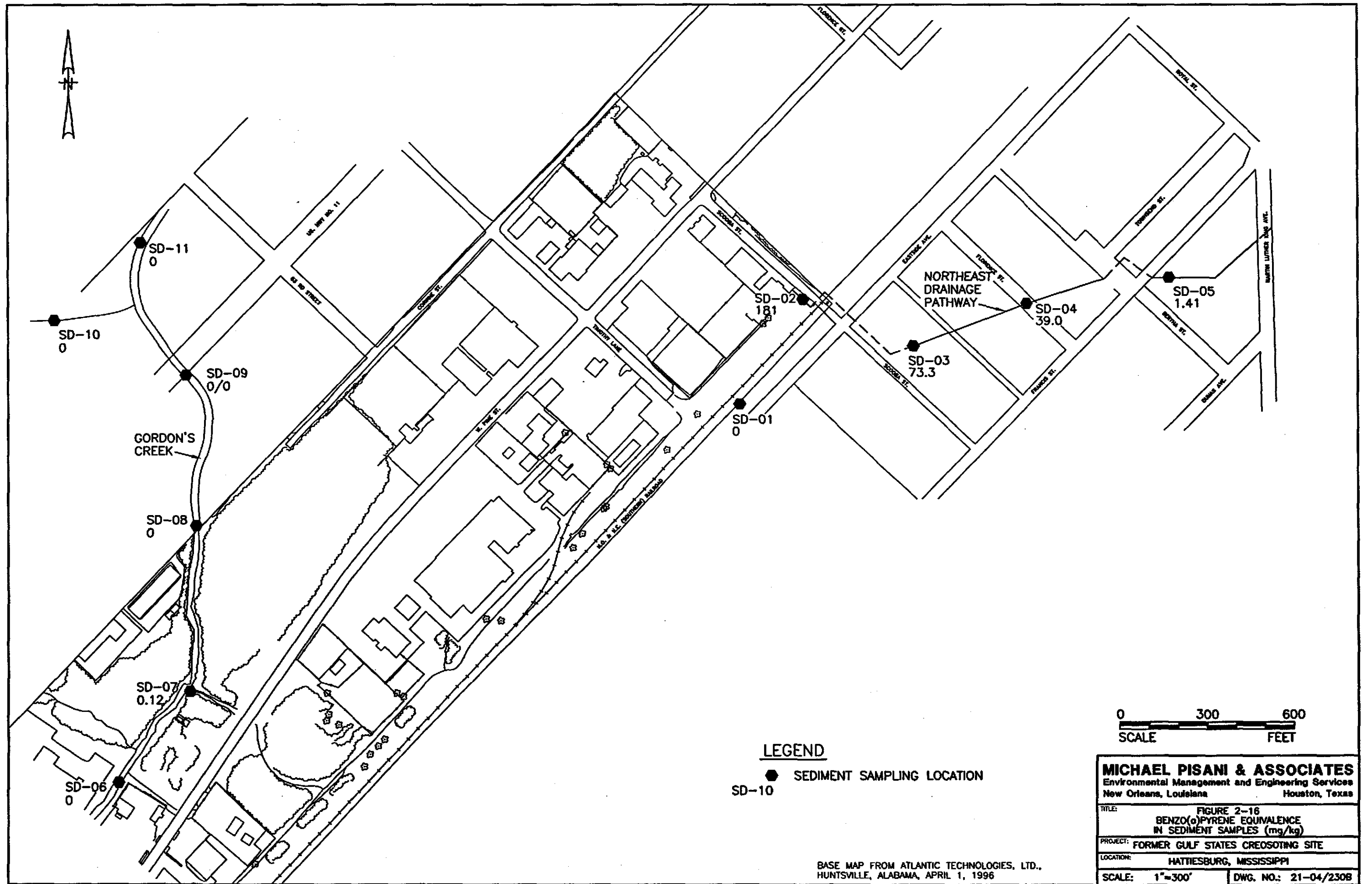

BASE MAP FROM ATLANTIC TECHNOLOGIES, LTD.,
HUNTSVILLE, ALABAMA, APRIL 1, 1996

MICHAEL PISANI & ASSOCIATES Environmental Management and Engineering Services New Orleans, Louisiana Houston, Texas	
TITLE:	FIGURE 2-16 BENZO(a)PYRENE EQUIVALENCE IN SEDIMENT SAMPLES (mg/kg)
PROJECT:	FORMER GULF STATES CREOSOTING SITE
LOCATION:	HATTIESBURG, MISSISSIPPI
SCALE:	1"=300' DWG. NO.: 21-04/2308

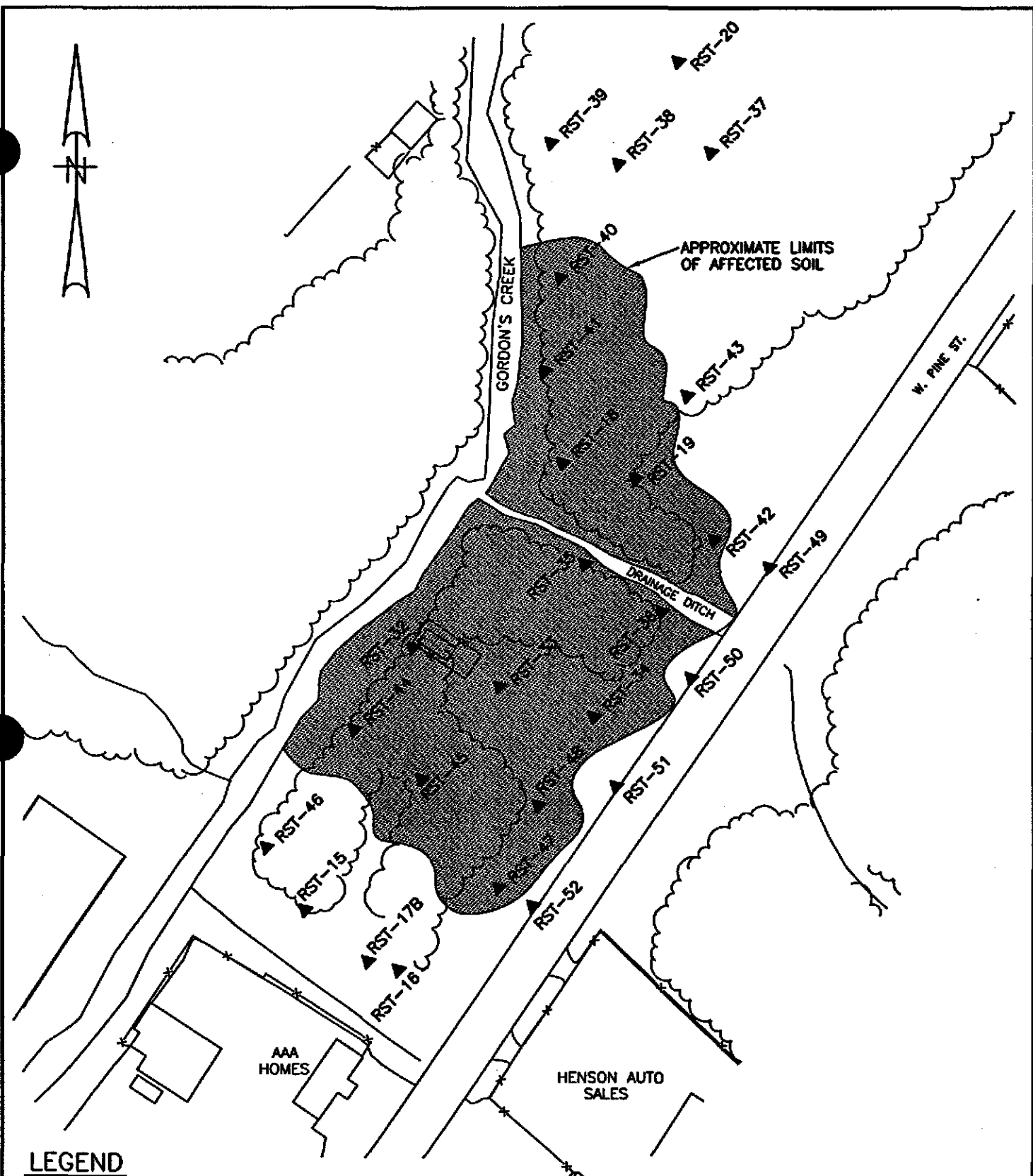

LEGEND

▲ ROST PUSH

BASE MAP FROM ATLANTIC TECHNOLOGIES, LTD.,
HUNTSVILLE, ALABAMA, APRIL 1, 1996

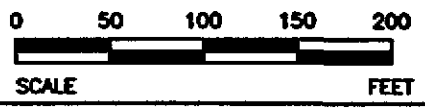

MICHAEL PISANI & ASSOCIATES
Environmental Management and Engineering Services
New Orleans, Louisiana Houston, Texas

SCALE: 1"=100' DWG. NO.: 21-04/231A

FIGURE 2-17
APPROXIMATE EXTENT OF AFFECTED SOIL
FILL AREA
FORMER GULF STATES CREOSOTING SITE
HATTIESBURG, MISSISSIPPI

Ground Water. The results of ground water sampling activities confirmed that the area containing affected ground water is similar to the overlying area of affected soil delineated during the RI, but that affected ground water extends northward from the Fill Area in a thin band along the east bank of Gordon's Creek. Figure 2-13 shows the approximate extent of affected ground water in the Fill Area. Data from monitoring well MW-13 indicates that affected Fill Area ground water has not migrated across Gordon's Creek.

DNAPL. No DNAPLs have been detected in any of the Fill Area monitoring wells. However, brown oily liquids were observed in a number of borings advanced within the Fill Area. These liquids appear to constitute thin layers of DNAPL perched upon thin, discontinuous clay layers beneath the Fill Area, at depths generally ranging from 5 to 20 feet below land surface (bls). These perched DNAPL zones are apparently the source of the intermittent seeps of DNAPLs into Gordon's Creek and the tributary ditch transecting the Fill Area.

2.2.2 Former Process Area/Southern Railroad Track Area

Soil. ROST and subsurface soil analytical data indicate that affected soils within the former Process Area are confined to areas beneath and/or immediately adjacent to former wood treating operational features. These features, as identified from historical Sanborn maps and aerial photographs, include a settling basin, oil storage tanks, the treating room, and "oil dumping tanks." Former wood treating operational features were confined to an area currently bounded by Timothy Street on the southwest, the Southern railroad ditch on the southeast, Scooba Street on the northeast, and a line roughly parallel to and approximately 200 feet east of West Pine Street on the northwest.

The approximate extent of affected soil within the former Process Area, based on the ROST data and subsurface soil results, is depicted by the shaded area on Figure 2-18. It appears that the migration of creosote constituents was limited by the low permeability of the upper clay, the highly adsorptive nature of the constituents, and the adsorbing capacity of the upper clay. The approximate surface area underlain by affected soils is 4.4 acres. The depth of affected soil in this area varies by location but ranges from approximately 5 feet bls to as deep as the top of ground water (20 to 25 feet bls).

The vast majority of affected soils within the former Process Area is currently covered with asphalt or large building structures. This precludes direct contact with affected soils and minimizes the potential infiltration of rainwater through these soils. The only unpaved area containing affected soils is an approximately 100-foot wide strip of property between the Courtesy Ford parking lot and the Southern railroad tracks.

Ground Water. Results of the RI indicate that ground water in the uppermost water-bearing zone beneath the former Process Area has been affected by former wood treating operations. Analytical data from onsite monitoring wells indicate that affected ground water does not extend westward or significantly southward from the former Process Area.

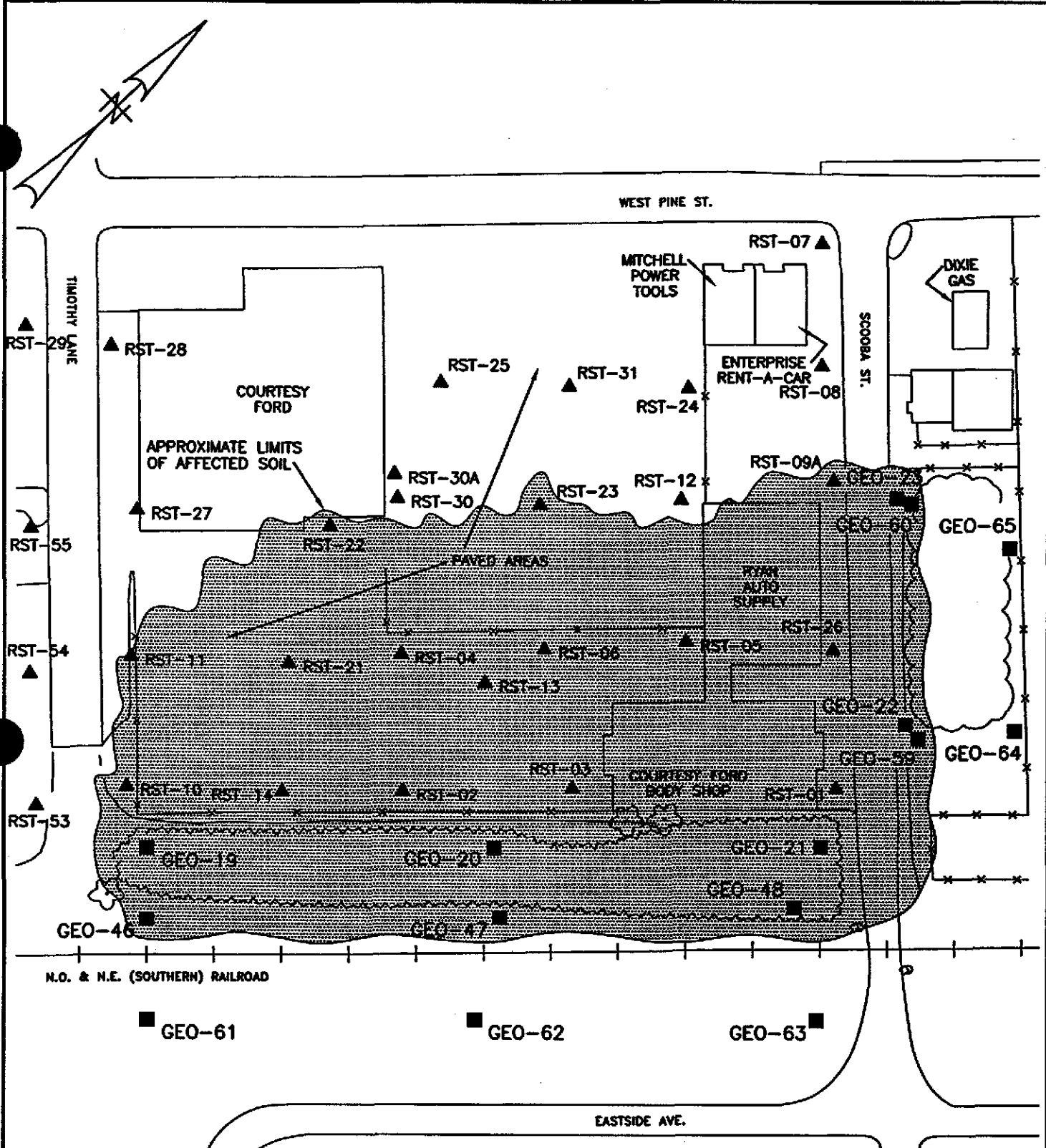

LEGEND

- ▲ ROST PUSH
- SOIL SAMPLING LOCATION

BASE MAP FROM ATLANTIC TECHNOLOGIES, LTD.,
HUNTSVILLE, ALABAMA, APRIL 1, 1996

MICHAEL PISANI & ASSOCIATES
Environmental Management and Engineering Services
New Orleans, Louisiana Houston, Texas

SCALE: 1"=100' DWG. NO.: 21-04/232A

FIGURE 2-18
APPROXIMATE EXTENT OF AFFECTED SOIL
FORMER PROCESS AREA
FORMER GULF STATES CREOSOTING SITE
HATTIESBURG, MISSISSIPPI

Creosote constituents, most notably naphthalene, were reported in samples from a number of downgradient wells and temporary well points. As shown on Figure 2-14, however, affected downgradient ground water actually exists in two separate and distinct plumes: one originating from the former Process Area and a second associated with the northeast drainage ditch. Ground water data from GEO/68A, along with data from GEO-56 and other previous sampling locations depicted on Figure 2-14, clearly demonstrate that the plume originating from the former Process Area and the plume associated with the northeast drainage ditch are not interconnected.

DNAPL. DNAPLs are not present in any of the monitoring wells within or downgradient of the former Process Area. In June 2001, exploratory excavation work was conducted to identify recoverable DNAPLs in several subsurface features beneath the former Process Area. Although MDEQ concurred that significant volumes of recoverable free product do not exist within these features, MDEQ considers saturated materials contained in a concrete sump and a wooden substructure to be potential sources of ongoing contamination that must be addressed in this plan.

3.0 Summary of Risk Assessment Findings

Creosote constituents of potential health concern at the Site include polycyclic aromatic hydrocarbons, of which benzo(a)pyrene is the predominant contributor to potential risks. Much of the former Process Area is currently covered with asphalt or large structures that preclude direct contact with affected materials. Potential future exposure scenarios considered in the assessment of risks included a construction worker, a maintenance worker, and an infrequent site visitor, and offsite residents. Media of concern included soils, sediment, and surface water.

Hazards posed by chemical constituents in soils, sediment, and surface water for health effects other than an increased risk of cancer were well below a threshold of possible concern for each receptor evaluated in the risk assessment. Cancer risks for all exposure scenarios were within or below the U.S. EPA's acceptable target risk range of 1×10^{-6} to 1×10^{-4} (i.e., one in one million to one in ten thousand) with two exceptions: 1) maintenance worker exposure to soils in the area between the former Process Area and the Southern railroad tracks; and 2) offsite resident exposure to sediments in the northeast drainage ditch. However, remedial actions proposed in this document and the *Removal Action Work Plan* for the northeast drainage ditch, including deed restrictions, will result in the removal of affected media and/or the elimination of exposure pathways thereby resulting in acceptable levels of risk to potential receptors.

4.0 Selection of Remedial Alternatives

A Feasibility Study (FS) was included in the February 14, 2000 *Remedial Action Work Plan*. A copy of the FS is provided as Appendix B of this document. The FS contained proposed remedies for the Fill Area, former Process Area subsurface features, and the Southern Railroad track area, as well as the northeast drainage ditch. Proposed remedies for each area were:

- Fill Area - vertical barrier, DNAPL recovery, in situ biological treatment, and monitored natural attenuation
- Former Process Area Subsurface Features - DNAPL recovery and monitored natural attenuation
- Southern Railroad Track Area - in situ biological treatment and monitored natural attenuation
- Northeast Drainage Ditch - removal and offsite disposal, installation of culvert, and monitored natural attenuation.

These proposed remedies have been reviewed and re-evaluated to take into consideration the results of investigative activities completed since submittal of the original *Remedial Action Work Plan* and MDEQ comments received on the original and revised plans. Although the basic remedial strategy for each area remains unchanged, the following additions and modifications have been made to remedies proposed in the original plan.

4.1 Fill Area

The original *Remedial Action Work Plan* called for in situ biological treatment of Fill Area soils. However, because of concerns over the potential for mounding of ground water behind the sheet piling barrier, this revised plan calls for capping and phytoremediation to address Fill Area soils and ground water. Details on these modifications are provided in Sections 5.1.5 and 5.1.6 of this plan.

4.2 Former Process Area Subsurface Features

The original plan called for the recovery of DNAPLs from former Process Area subsurface features. Investigations conducted since the submittal of the original plan have confirmed that: a) significant volumes of recoverable free product do not exist within these features; and b) saturated materials considered by MDEQ to be potential sources of ongoing contamination are confined to a concrete sump and a wooden substructure within the former Process Area. Therefore, Section 5.2.1 of this plan describes procedures for removal and offsite disposal of free product and creosote-saturated materials within and adjacent to these features.

4.3 Southern Railroad Track Area

The original plan called for in situ biological treatment of affected soils between the former Process Area and the Southern railroad tracks. However, MDEQ expressed concerns regarding the depth of treatment, and in situ biotreatment would potentially require

numerous treatment events over an extended period of time to accomplish the desired results. Therefore, this revised plan calls for the removal and offsite disposal of free product and creosote-saturated soils within ditches in the Southern railroad track area, followed by the capping of the entire area. Details on these proposed modifications are provided in Section 5.3 of this plan.

4.4 Northeast Drainage Ditch

The proposed remedy for the northeast drainage ditch, which was presented in the August 3, 2001 *Removal Action Work Plan*, remains essentially unchanged from the original plan.

5.0 Recommended Remedial Action

The following subsections describe the specific tasks that will be completed to achieve remedial action objectives for the Fill Area, former Process Area subsurface features, and the Southern railroad track area. In addition to the specific remedial actions described in Sections 5.1 through 5.3, institutional controls (e.g., land use restrictions and operational restrictions) will be deed recorded on affected portions of the property to ensure that: a) the future use of the affected areas of the Site is consistent with their current use (i.e., commercial and/or industrial); and b) current and future Site owners and/or lessees of the affected areas are advised of the presence of affected media and restrictions on land use.

5.1 Fill Area

The remedial action objectives for the Fill Area are to: 1) eliminate the intermittent seepage of DNAPLs from the Fill Area into Gordon's Creek; 2) delineate the extent of visible DNAPLs within the Gordon's Creek streambed and develop a plan to remediate visible DNAPLs, if necessary; 3) collect and remove DNAPLs perched on shallow, discontinuous clay layers within the Fill Area to the extent practicable; 4) inhibit the infiltration of precipitation through affected soils; 5) promote the capture of affected ground water and accelerate further degradation of site constituents in shallow soils; and 6) demonstrate that natural attenuation of constituents in ground water is occurring outside of the containment area.

Further seepage of DNAPLs into Gordon's Creek will be prevented by the placement of a low-permeability vertical barrier constructed of steel sheet pilings. The extent of DNAPLs within the Gordon's Creek streambed will be assessed by collecting sediment cores adjacent to and downstream of the Fill Area. DNAPLs that accumulate as perched liquids within the Fill Area will be collected and removed utilizing a system of recovery wells installed on the upgradient side of the sheet piling barrier. The potential for infiltration of precipitation through affected soils will be greatly reduced by placement of a cap atop affected Fill Area materials. A phytoremediation program will be implemented to reduce the potential for ground water mounding, promote the capture of affected ground water, and accelerate further degradation of site constituents in shallow soils. Ground water monitoring necessary to demonstrate natural attenuation of site constituents will also be performed.

5.1.1 Culvert Installation

The Fill Area is bisected by a drainage ditch that runs from the Southern railroad ditch under West Pine Street to Gordon's Creek. DNAPL, affected subsurface soil, and affected ground water are present between West Pine Street and Gordon's Creek on both sides of the drainage ditch (see Figure 5-1). As part of the Fill Area remedy, a sheet piling barrier will be installed along the bank of Gordon's Creek to prevent episodic seepage of DNAPL to the creek. In order to allow for continued surface drainage, the drainage ditch between West Pine Street and Gordon's Creek will be replaced with a concrete culvert, routed along the original ditch and through the sheet piling barrier.

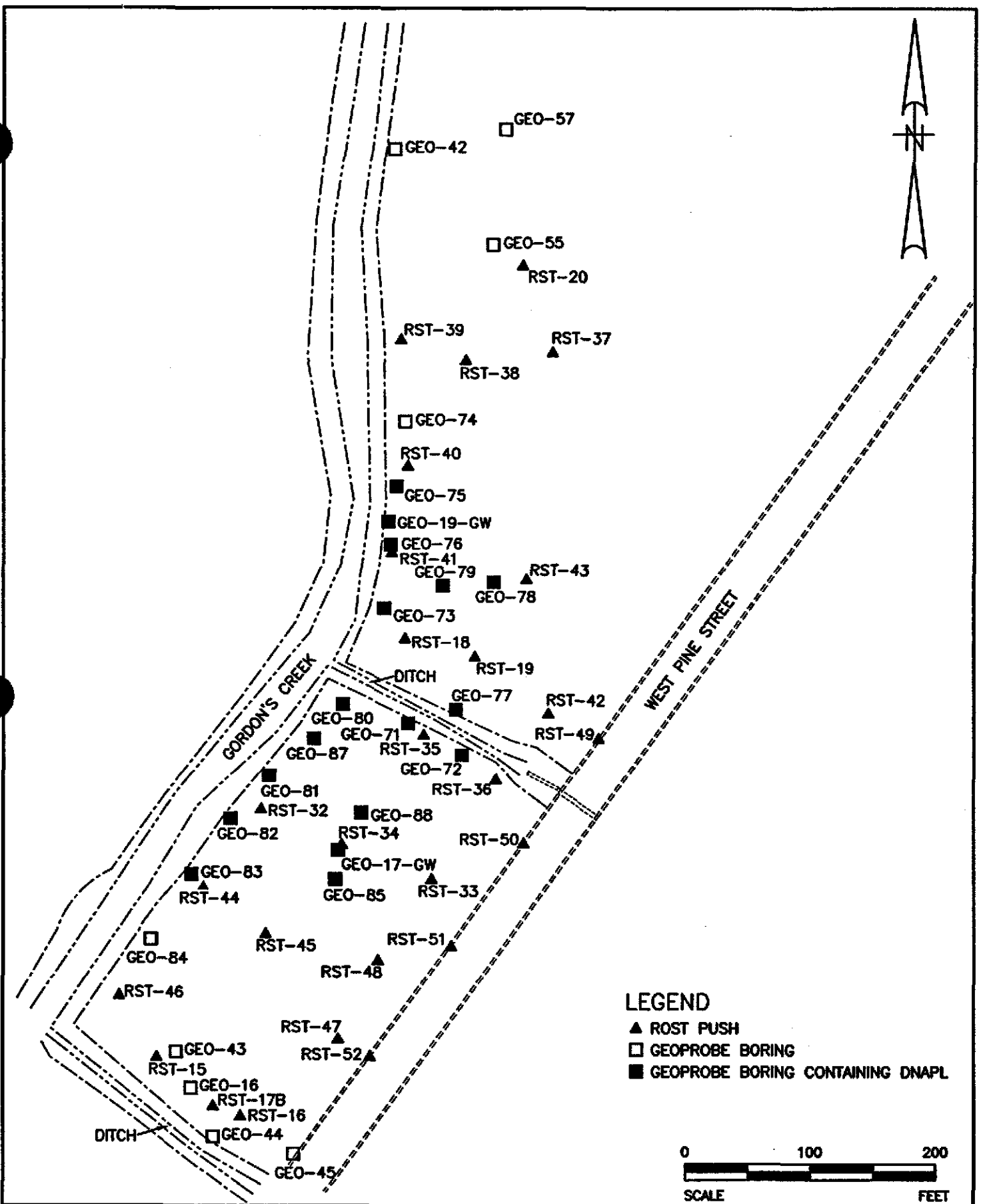

MICHAEL PISANI & ASSOCIATES
 Environmental Management and Engineering Services
 New Orleans, Louisiana Houston, Texas

SCALE: 1"=100' DWG. NO.: 21-04/222A

FIGURE 5-1
ROST AND GEOPROBE LOCATIONS
FILL AREA
FORMER GULF STATES CREOSOTING SITE
HATTIESBURG, MISSISSIPPI

The culvert will direct surface drainage through the sheet piling barrier at an elevation above any perched DNAPLs in the Fill Area. The culvert will be wrapped in a polyethylene liner and placed on a sand bed within the base of the existing ditch. The sand bed and culvert will be constructed to slope toward Gordon's Creek. The culvert pipe will be covered with sandy soil backfill, seeded with native grass seed, and fitted with grated storm water inlets. The culvert, culvert bedding, and backfill material will be placed in accordance with applicable City of Hattiesburg specifications for storm water collection and conveyance systems.

5.1.2 Sheet Piling Barrier

During the RI, the extent of affected soil in the Fill Area was delineated using the ROST system and confirmatory soil samples. In July 2001, a soil boring program was undertaken in the Fill Area to obtain additional information necessary to fully develop the Fill Area remedy. The purpose of this program was to evaluate the thickness and lateral continuity of clay layers above the top of the Hattiesburg clay (i.e., within the first 20 to 30 feet below grade) and to delineate the extent of perched DNAPLs.

The locations of all ROST pushes and Geoprobe borings advanced within the Fill Area are depicted on Figure 5-1. The 17 borings advanced during July 2001 were all advanced several feet into the Hattiesburg clay. No laterally continuous clay layers were identified above the top of the Hattiesburg clay, which was encountered at depths ranging from 20 to 27 feet below grade, or elevations of 158 to 165 feet above mean sea level (amsl). Boring logs from the July 2001 boring program are provided in Appendix C.

Soil boring logs and ROST logs were reviewed to determine the vertical and horizontal extent of DNAPL within the Fill Area. The logs indicate that DNAPL is distributed as discontinuous pools of liquids perched upon lenses of less permeable materials (i.e., clayey and silty materials) above the Hattiesburg clay. DNAPLs were not encountered in any boring at depths exceeding 21 feet below land surface, with the majority of DNAPL encountered at depths ranging from 5 to 15 feet below grade.

Because no laterally continuous clay layers of significant thickness were identified above the top of the Hattiesburg clay, the sheet piling wall will be keyed into the Hattiesburg clay. Sealable-joint sheet pilings will be driven near the top of the bank of Gordon's Creek, with "wing walls" for the containment area extending approximately 150 feet eastward toward West Pine Street (Figure 5-2). Pilings will be driven to a common elevation of 156 feet amsl, or 2 to 9 feet into the Hattiesburg clay.

Sealable-joint sheet pilings are similar to conventional pilings, but have interlocking joints between individual pilings that incorporate a cavity. After driving, this cavity will be filled with sealant to prevent leakage through the joints (Figure 5-3). Standard pile driving equipment and techniques will be used to construct the vertical barrier. A footplate at the bottom of each cavity displaces soil as the pilings are driven, keeping the joints largely soil-free. A water-tight sealant, as recommended by the piling manufacturer for permanent installations, will then be injected into the sealable cavities to minimize the potential for

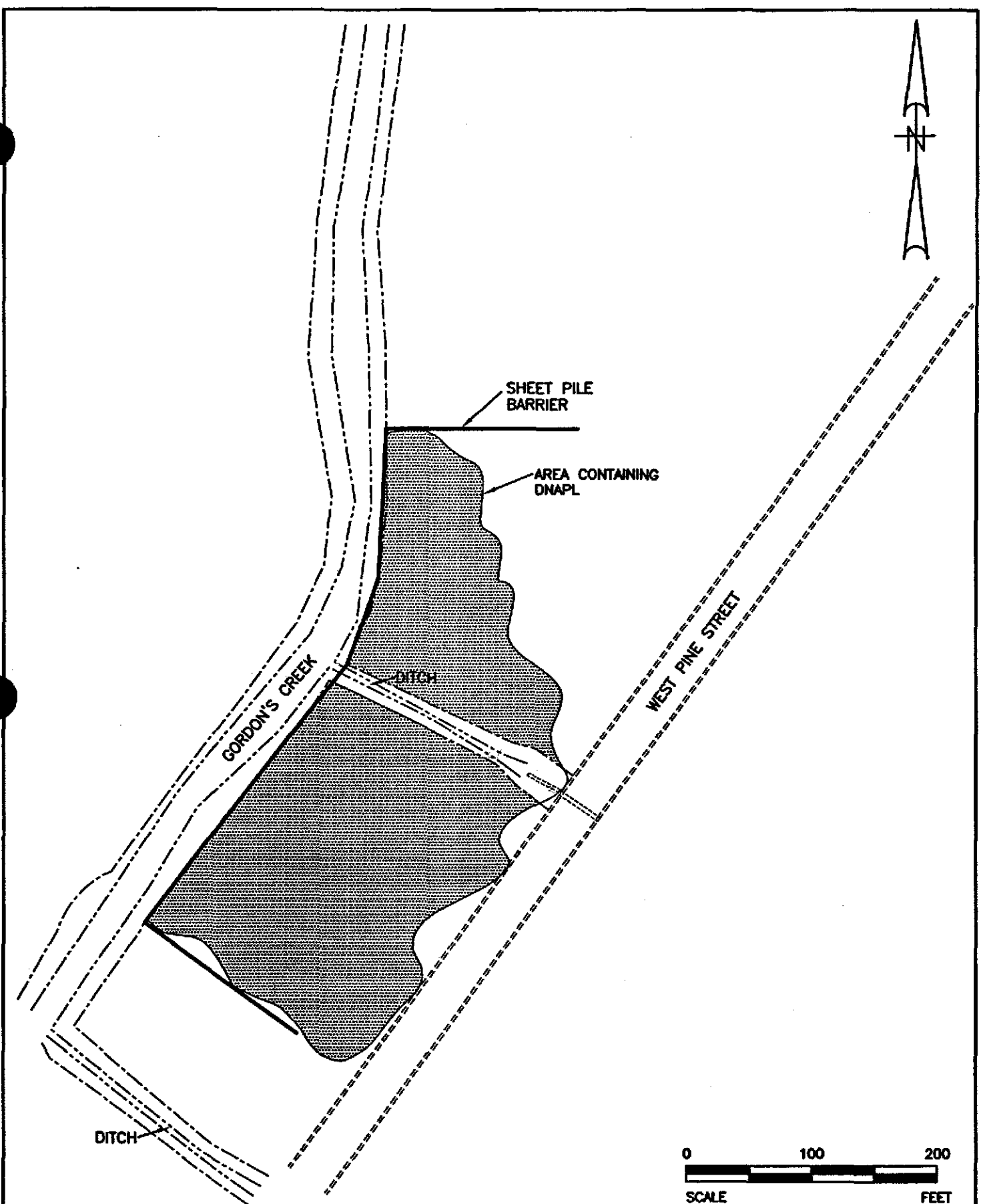

MICHAEL PISANI & ASSOCIATES
 Environmental Management and Engineering Services
 New Orleans, Louisiana Houston, Texas

SCALE: 1"=100' DWG. NO.: 21-04/233A

FIGURE 5-2
 CONFIGURATION OF SHEET PILE BARRIER
 FILL AREA
 FORMER GULF STATES CREOSOTING SITE
 HATTIESBURG, MISSISSIPPI

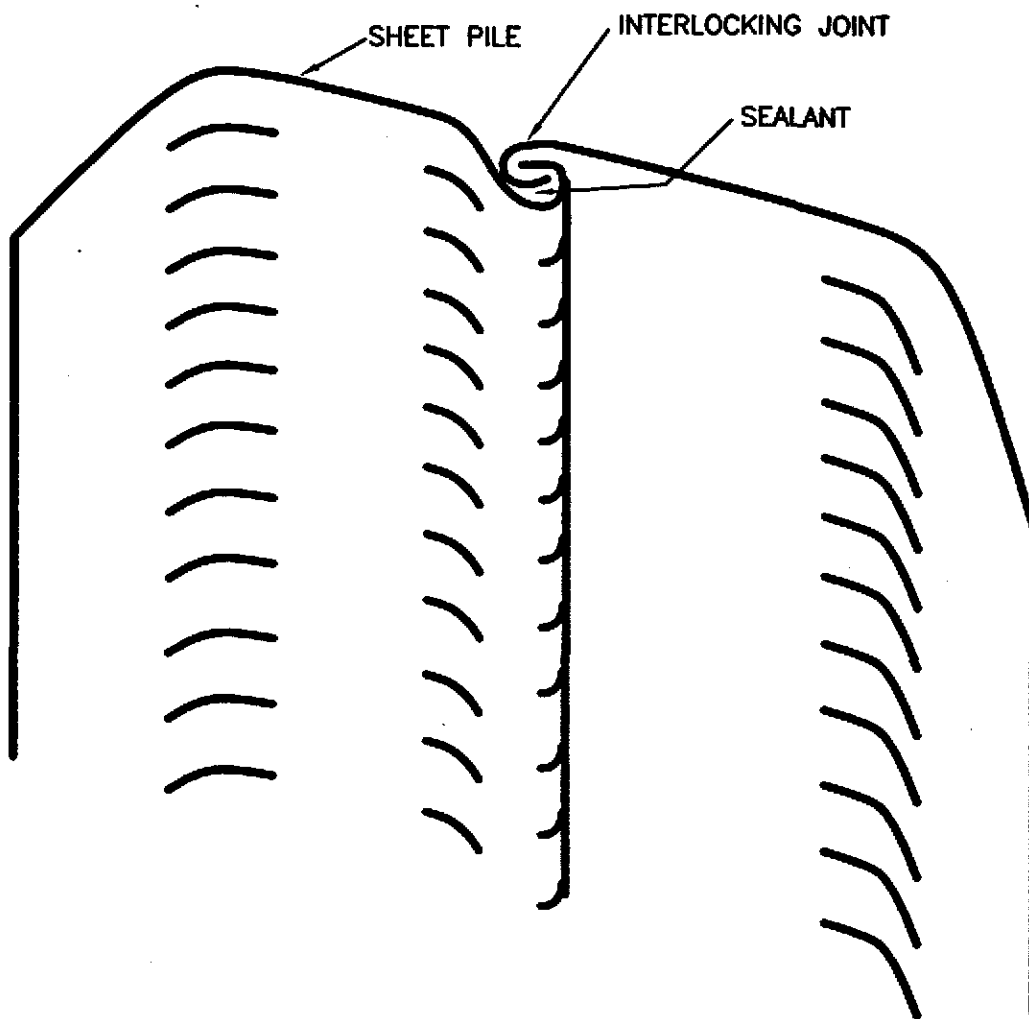

MICHAEL PISANI & ASSOCIATES
Environmental Management and Engineering Services
New Orleans, Louisiana Houston, Texas

SCALE: NTS

DWG. NO.: 21-04/238A

FIGURE 5-3
SEALABLE SHEET PILE JOINT

FORMER GULF STATES CREOSOTING SITE
HATTIESBURG, MISSISSIPPI

leakage between individual pilings. Additional information on sealable-joint pilings is provided in Appendix D.

The primary purpose of the vertical barrier is to cut off the potential for migration of DNAPLs. The ground water regime within the Fill Area is extremely localized, as the shallow water-bearing zones beneath the Fill Area do not extend to the east of West Pine Street. Once the geosynthetic clay liner (GCL) is installed (see Section 5.1.5) and the phytoremediation system is in place (see Section 5.1.6), the potential for ground water mounding behind the barrier will be minimal. Nonetheless, water levels in the monitoring/recovery wells behind the sheet piling barrier (see Section 5.1.4) will be gauged as part of the post-closure monitoring. If it appears that affected ground water is migrating around the downgradient wing wall, ground water can be extracted from monitoring/recovery wells or the wall can be extended.

5.1.3 Gordon's Creek DNAPL Assessment

Surface water and sediment in Gordon's Creek were sampled and analyzed during the RI. Although target constituents were detected in some samples, risk assessment results indicated that constituent concentrations in surface water and sediment did not pose unacceptable risks to human health. However, episodic seepage of DNAPLs from the bank of the Fill Area into Gordon's Creek has been observed in the past.

The surficial sediments within the Gordon's Creek streambed are comprised predominantly of sand and gravel. Limited assessment activities, consisting primarily of probing within the base of the channel, indicate that these sand and gravel deposits are typically 1 to 2 feet thick and are underlain by a clay layer. This clay layer extends beneath the east bank of Gordon's Creek into the Fill Area, and apparently acts as a horizontal barrier on which DNAPLs pool. Because the surface of the clay layer slopes slightly toward Gordon's Creek, DNAPLs have migrated toward the creek along the clay's surface and seeped into the creek. DNAPLs have been observed within the creek bed at the interface between the sand/gravel layer and the underlying clay. The extent of DNAPLs in the creek, however, is unknown.

A sediment coring program will be undertaken to assess the extent of DNAPLs within the creek bed. Cores of the sediment column will be collected at regular intervals (approximately every 150 feet) within the creek bed and will be visually logged for the presence of DNAPLs (see Figure 5-4). Sediment cores will be collected by driving a core barrel equipped with clear plastic liners to the base of sand and gravel sediments. The sampler will be driven several inches into the underlying clay or to the base of visible contamination. In no case will the sampler be driven to depths greater than 4 feet below the top of the sediment.

Once assessment activities have been completed, the results will be evaluated and a map depicting the vertical and lateral extent of free product and/or creosote-saturated material will be generated. A plan to remediate sediments/soils containing visible DNAPLs, if required, will be submitted to MDEQ as an addendum to the *Remedial Action Work Plan*.

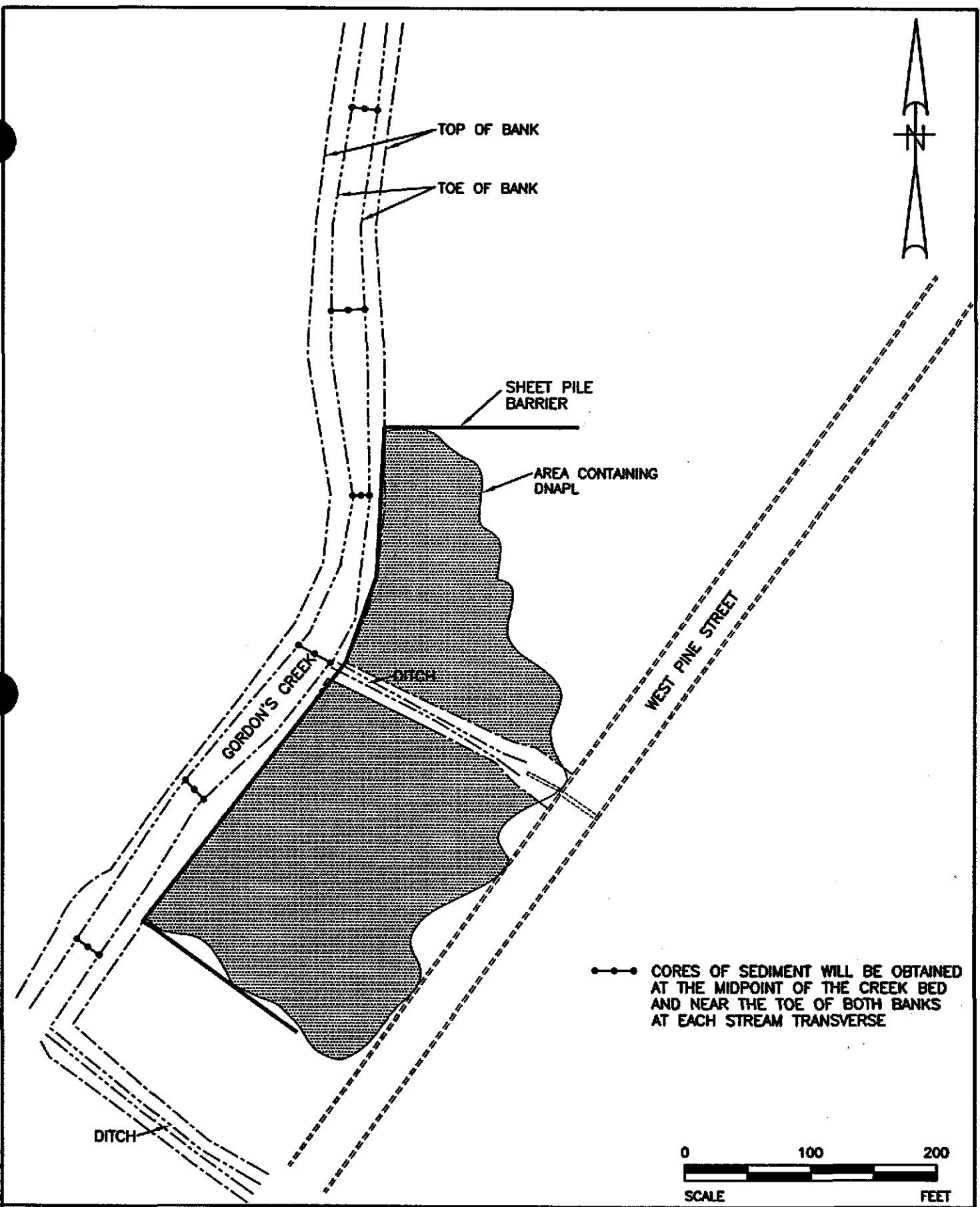

MICHAEL PISANI & ASSOCIATES
 Environmental Management and Engineering Services
 New Orleans, Louisiana Houston, Texas

SCALE: 1"=100' DWG. NO.: 21-04/278A

FIGURE 5-4
 SEDIMENT CORING LOCATIONS
 GORDON'S CREEK
 FORMER GULF STATES CREOSOTING SITE
 HATTIESBURG, MISSISSIPPI

5.1.4 DNAPL Recovery and Monitoring System

A recovery system will be installed on the upgradient side of the sheet piling barrier to collect and remove DNAPLs that accumulate behind the barrier. It is anticipated that the recovery system will consist of the following elements:

- recovery wells placed at approximately 25-foot intervals behind the barrier to allow for the collection of DNAPLs. Each recovery well will be screened across the entire thickness of DNAPLs encountered during the drilling of the borehole for the well.
- drop tubes extending from the base of each recovery well to land surface. Drop tubes will be equipped with appropriate hardware (e.g., cam-locks or other "quick-connects") at the surface to allow for easy hook-up to a pump or portable recovery system.
- monitoring wells placed at approximately 50-foot intervals behind the sheet piling barrier to monitor for the presence of DNAPLs to the top of the Hattiesburg clay. Each monitoring well will be screened at the contact between the saturated Fill Area sands and the Hattiesburg clay.

Figure 5-5 is a schematic drawing of the proposed DNAPL recovery and monitoring system. Proposed locations of recovery and monitoring wells are shown on Figure 5-6.

During the first six months after installation of the system, recovery wells and monitoring wells will be gauged monthly for the presence of DNAPL. Those wells containing DNAPLs will be pumped to an onsite holding tank for subsequent offsite transportation and re-use or treatment/disposal. Drop tubes will be installed to convert any monitoring wells containing DNAPLs into recovery wells. If after six months it is apparent that monthly DNAPL gauging and recovery are unnecessary, the program will be modified to gauge and recover DNAPLs at an appropriate frequency.

5.1.5 Installation of Geosynthetic Clay Liner

Once the sheet piling barrier is in place, ground water will no longer be allowed to discharge from the Fill Area into Gordon's Creek. Two steps will be taken to minimize the potential for ground water mounding behind the barrier. First, a geosynthetic clay liner will be placed atop affected Fill Area materials. This will not only minimize the potential for ground water mounding, but will also greatly reduce the potential for infiltration of precipitation through affected Fill Area materials. Secondly, trees with the ability to uptake large volumes of water will be planted throughout the Fill Area. Details on the phytoremediation program are provided in Section 5.1.6.

A geosynthetic clay liner (GCL) will be placed atop the shaded area shown on Figure 5-2. The liner to be used consists of a layer of sodium bentonite between a geotextile and a laminate comprised of a geotextile and a polyethylene membrane which are continuously adhered together. The GCL will be placed with approximately 12 inches of overlap at the joints between panels.

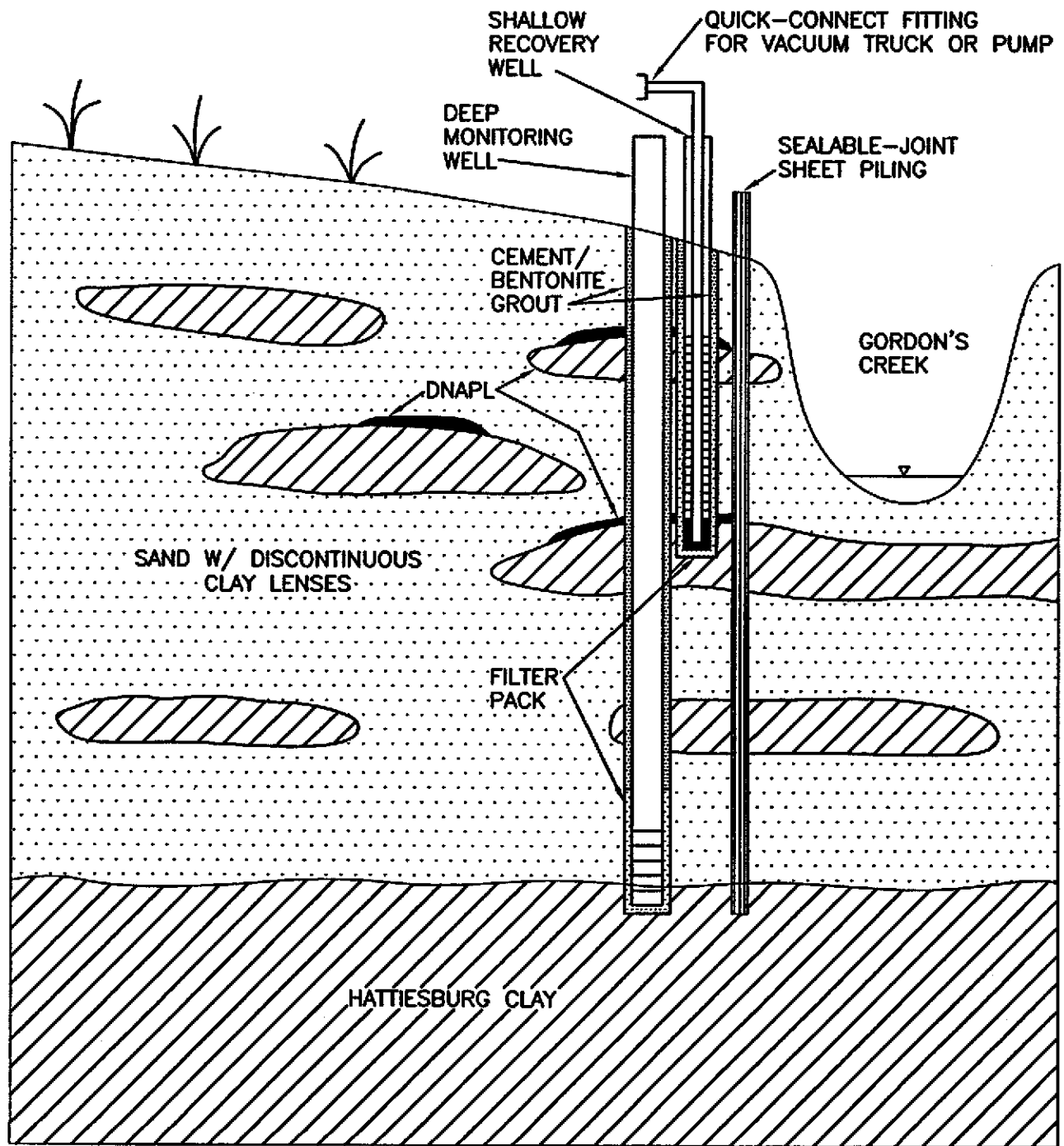

MICHAEL PISANI & ASSOCIATES
 Environmental Management and Engineering Services
 New Orleans, Louisiana Houston, Texas

FIGURE 5-5
 DNAPL RECOVERY AND MONITORING SYSTEM SECTION VIEW
 FILL AREA

FORMER GULF STATES CREOSOTING SITE
 HATTIESBURG, MISSISSIPPI

SCALE: NTS

DWG. NO.: 21-04/234A

5.1.6 Phytoremediation

Phytoremediation is the direct use of plants to contain, immobilize, degrade, or remove contaminants from affected water and soils. The following are the primary mechanisms by which organic contaminants are phytoremediated: evaporative transpiration, rhizodegradation, phytotransformation, and phytovolatilization.

Evaporative Transpiration is the use of trees as hydraulic controls, whereby their root masses reach down to the water table and take up large quantities of water. This ground water uptake can serve to control the migration of a contaminant plume in ground water by eliminating or reducing the forward flow of ground water. Poplar trees, for example, have been reported to transpire up to 50 gallons per day per tree.

Rhizodegradation is the breakdown of contaminants in the soil and ground water through microbial activity that is enhanced by the presence of the root zone (or *rhizosphere*). Substances produced by the plant roots, also known as plant *exudates*, can stimulate the degradation of organic contaminants in the soil and ground water and also reduce the mobility of certain contaminants (e.g., metals) in ground water by making them less soluble.

Phytotransformation is the breakdown of contaminants taken up by plants through metabolic processes within the plant or by the breakdown of contaminants outside the plant (i.e., in the soil/root contact zone) by enzymes or other compounds produced by the plants.

Phytovolatilization is the uptake and transpiration of volatile contaminants by plants, with the release of either the contaminant compound or breakdown daughter compounds to the atmosphere from the plants. As plants take up ground water and contaminants, some of the contaminants pass through the plants to the leaves, where the compounds evaporate, or *volatilize*, into the atmosphere.

The phytoremediation portion of the remedy for the Fill Area will be designed to optimize the evaporative transpiration of ground water to reduce or prevent the mounding or accumulation of ground water upgradient of the subsurface barrier at the site. Additional removal of organic contaminants in soil and ground water may be accomplished by other mechanisms as described above.

Preliminary Evaluation

Prior to completing the final design for the phytoremediation program, a preliminary evaluation will be completed. This evaluation will include a survey of existing trees at the site, research into trees indigenous to the area, and a review of the latest technical literature on phytoremediation. A detailed plan proposing types of trees and planting frequency will be submitted to MDEQ for review and approval within 60 days of installation of the sheet piling barrier.

Phytoremediation Conceptual Design

The phytoremediation remedy described in this section consists of planting trees in rows through out the Fill Area. A schematic cross-sectional drawing of the proposed tree planting design is provided as Figure 5-7. The approximate extent of the proposed tree planting areas is shown on the plot plan presented as Figure 5-8.

Phreatophytes such as hybrid poplars, willows, cottonwoods, and eucalyptus are most frequently selected for use in phytoremediation projects because of fast growth, deep rooting ability, large transpiration rates, and the fact that they are native throughout most of the country. Some of these trees (e.g., eucalyptus) have demonstrated high growth rates even during the winter months at sites within the Gulf Coast region. The use of multiple species will minimize the risk of losing all the trees to drought, a sudden frost or other rapid change in environmental conditions at the site.

Conceptually, approximately 600 trees will be planted in two stands of 300 in the Fill Area on either side of the east-west drainage ditch that flows into Gordon's Creek. The tree line will be planted in staggered rows at a linear spacing of one tree approximately every ten feet, and the rows will be placed approximately ten feet apart. Extensive clearing of existing trees and under growth will be conducted in the Fill Area in preparation for the installation of the sheet piling and containment cap. Where feasible, well-established hard woods may be left in place and not cleared.

In addition to the trees planted to augment the hydraulic control and mitigate plume migration, a control group of approximately 80 trees will be planted upgradient of the affected soil in the fill area. The control group of trees will be planted in a rectangular stand in the field located immediately south of the Fill Area.

A minimum 20-foot wide tree-free buffer zone between the planted trees and the Fill Area boundaries will be maintained to allow access to fences, sheet piling, and recovery and monitoring wells. The main objective of the selected tree placement is to maximize the long-term evaporative transpiration of ground water affected with site-related constituents.

Tree Planting and Monitoring

In order to facilitate tree planting, holes will be cut in the liner and boreholes will be advanced at each tree-planting location. The liner will allow precipitation to enter the subsurface only at tree-planting locations, thereby directing precipitation to the sites where water is needed. The trees will be irrigated as necessary until their roots reach the water table. Even during drought conditions, it is not anticipated that the water table will fall to levels below the base level of Gordon's Creek (i.e., 7 to 10 feet below land surface).

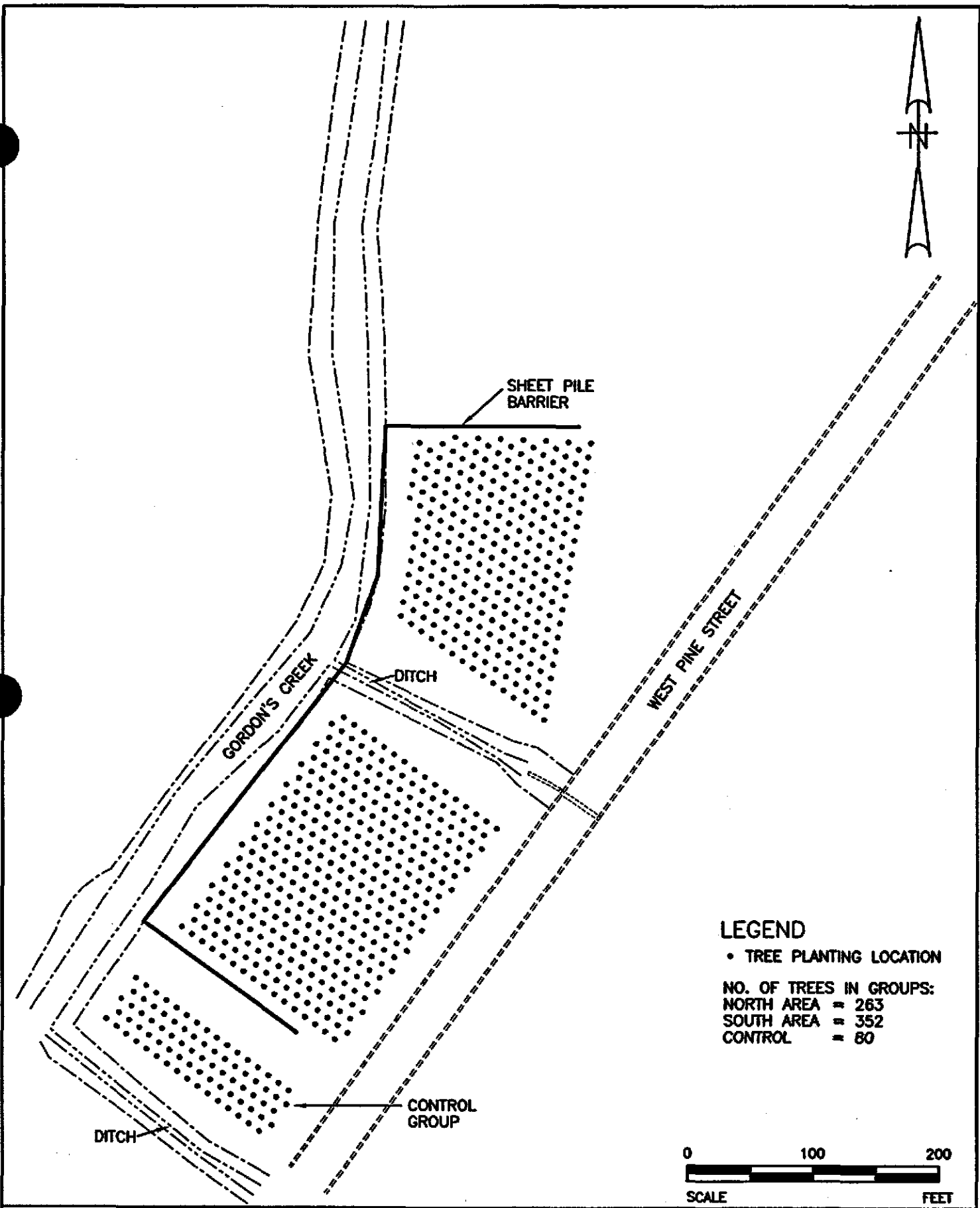





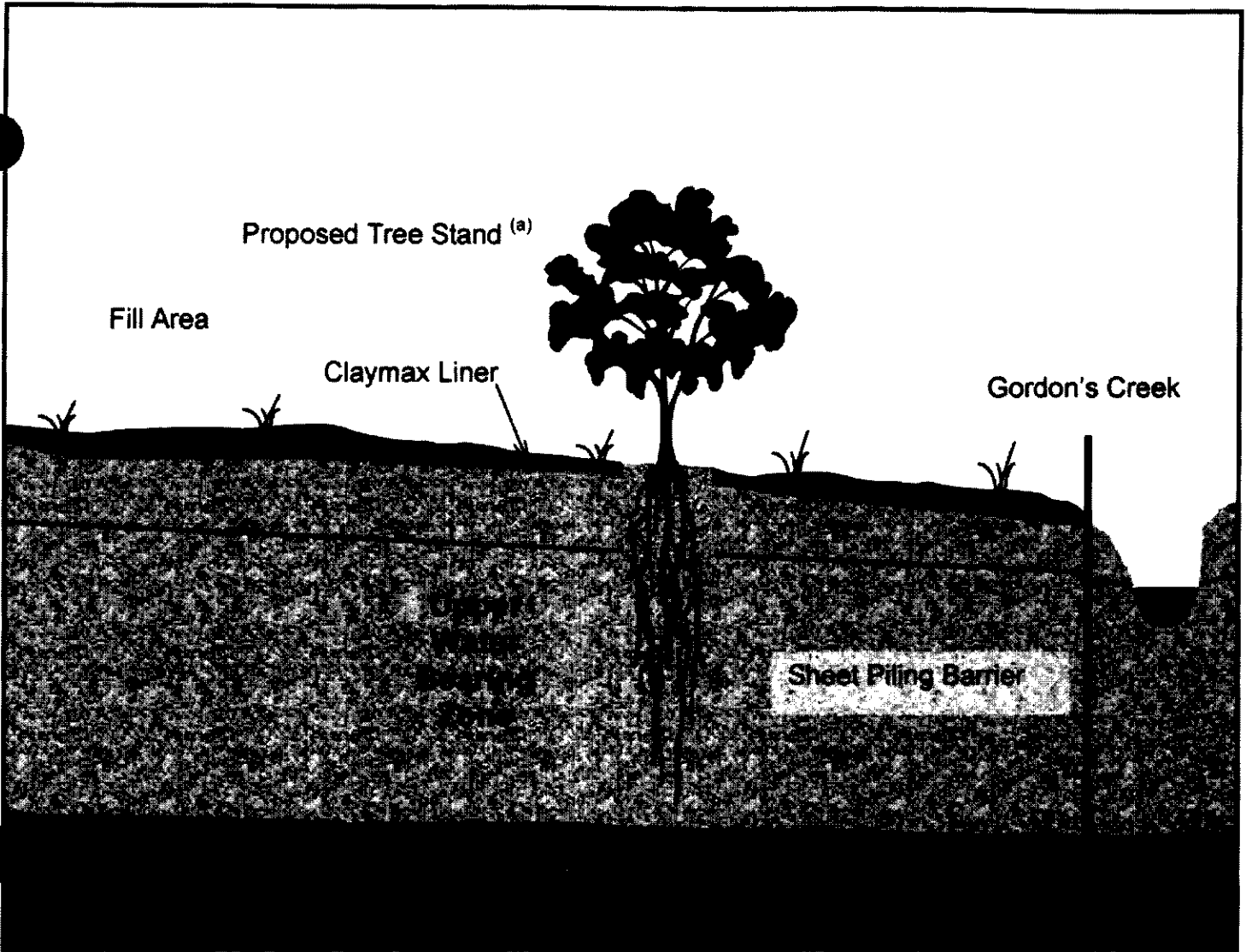

MICHAEL PISANI & ASSOCIATES
 Environmental Management and Engineering Services
 New Orleans, Louisiana Houston, Texas

SCALE: 1"=100' DWG. NO.: 21-04/223A

FIGURE 5-8
 DIAGRAM OF TREE PLANTING AREAS
 FILL AREA
 FORMER GULF STATES CREOSOTING SITE
 HATTIESBURG, MISSISSIPPI



LEGEND

-  Clay and Silty Clay
-  Sand
-  Sand and Mulch Mixture
-  Top Soil
-  Surface of Ground Water
-  Claymax Liner

NOTES

(a) Approximately 700 trees planted in three separate stands

<p>MICHAEL PISANI & ASSOCIATES Environmental Management & Engineering Services New Orleans, Louisiana Houston, Texas</p>	
<p>Figure 5-7</p>	
<p>Schematic Diagram Of Proposed Tree Line</p>	
<p>Gulf Coast Creosoting Fill Area</p>	
<p>Hattiesburg, Mississippi</p>	
<p>SCALE: DRAWING NOT TO SCALE</p>	<p>DWG. NO.:</p>

Boreholes for tree planting will be advanced to approximately 6 feet below grade. Cuttings will be planted to a depth of approximately 5 feet, with 1 foot of cutting protruding from the ground. Prior to placement of each cutting in the ground, root growth hormone will be applied to the cutting to stimulate root growth. Potted trees, which have an established root ball, will be planted at a depth of approximately 18 inches. Prior to planting the trees or cuttings, boreholes will be prepared with time-release fertilizer. In addition, the boreholes will be backfilled with a mixture of mulch and sand to provide optimum soil conditions for growth within the borehole. Soil cuttings will be placed in a section of the Fill Area under the geosynthetic clay cap (see Section 5.1.5).

To maintain a dense root network in the proposed tree stands, the planted trees will be thinned out only as appropriate. At the end of the first year after planting, the planted trees will be evaluated by an agricultural specialist to determine how many trees (if any) should be thinned. Thereafter, the planted tree stands will be thinned annually on as-needed basis.

Depth to ground water in and around the Fill Area is approximately 7 to 10 feet below grade, based on hydrogeological data collected during the RI. Due to the characteristics of the subsurface geology, no physical enhancements (i.e., tree collaring) will be required to train tree roots to grow deeper to ground water.

The trees will initially be irrigated at a rate comparable to 1 to 2 inches of rainfall per week. A drip irrigation system will be installed to provide water from the local municipal water supply to the trees during their first six months of growth, when necessary. The irrigation system will be operated on either a batch or timed-flow basis at a watering rate recommended by an independent forestry consultant or agricultural expert.

It is anticipated that some planted trees or cuttings may not take root. According to USEPA, a 10% to 20% initial mortality rate can be expected under ideal conditions, and initial mortality rates can range as high as 40% or 50%, depending upon the season during which the trees are planted. In addition, some mortality may occur after the planted trees take root. Tree mortality after planting may be caused by environmental changes (e.g., weather, excessive storm water ponding, drought, disease, etc.) or by potentially toxic concentrations of site-related constituents in ground water taken up by the trees. The control group of trees planted south of the Fill Area will provide baseline performance data against which tree growth within the ground water plume will be compared. In general, an 80% survival rate is considered successful for this type of project.

Growth performance of the trees will be monitored by periodically measuring average trunk girth and canopy height as well as other growth parameters. The growth performance parameters of the planted areas will be evaluated and the tree maintenance program will be modified as needed to optimize tree growth.

Projected Effectiveness

Trees including poplars and willows have been used at a number of sites to phytoremediate ground water contaminated with petroleum hydrocarbons and PAHs. As discussed previously, these tree types transpire significant quantities of ground water through their roots and evaporate it into the atmosphere. In addition, the tree roots utilize enzymes, which aid in the biodegradation of organic compounds in ground water absorbed by the trees. Results of these studies indicate that this technology is a feasible means of reducing concentrations of organic compounds in ground water.

Projected evaporative transpiration based on 50 gals/day/tree indicates that a mature stand of 700 trees in the fill area will pump up to 35,000 gallons per day. The limited recharge of ground water and the hydraulic controls provided by the subsurface barrier and phytoremediation, combined with a geosynthetic clay liner, are projected to effectively reduce the potential for ground water mounding behind the sheet piling wall.

5.1.7 Monitored Natural Attenuation

Monitored natural attenuation (MNA) is a potentially viable technology for addressing site constituents in ground water. MNA is a proven and widely-accepted remedial technology whereby natural processes such as biodegradation, dispersion, dilution, sorption, and volatilization combine to remediate affected media. A growing volume of data and case studies supports the viability of this technology and provides the basis for evaluating the occurrence and effectiveness of MNA.

A *Ground Water Monitoring Plan* for the site was submitted to MDEQ on June 25, 2001. MDEQ approved the plan for implementation in a letter dated July 17, 2001. The plan calls for a minimum of two years of quarterly sampling. After two years, the data will be evaluated and KMC may request MDEQ approval to modify the monitoring frequency.

The plan calls for monitoring wells both inside and outside of the containment area to establish that natural attenuation of constituents in ground water is occurring. Once the DNAPL recovery system has been in place and operating for a period of approximately three years, additional monitoring wells within the containment area may be added to the program to monitor the effects of DNAPL recovery and phytoremediation on ground water quality behind the sheet piling barrier.

5.2 Process Area Subsurface Features

The remedial action objectives for the former Process Area are to: 1) remove free product and creosote-saturated materials from historical subsurface features; 2) preclude direct contact with and minimize the potential for infiltration of precipitation through affected soils left in place; and 3) demonstrate that natural attenuation of constituents in ground water is occurring.

Materials considered to be potential sources of ongoing contamination (i.e., free product or creosote-saturated materials within or adjacent to a concrete sump and a wooden substructure within the former Process Area) will be removed and transported offsite for disposal at an acceptable location. Affected soils left in place will be capped with a water-impervious liner covered with asphalt to preclude direct contact and minimize the potential for infiltration of precipitation. Ground water monitoring necessary to demonstrate natural attenuation of site constituents will also be performed.

5.2.1 Results of Limited Excavation Activities

In June 2001, limited excavation work was conducted within the former Process Area to delineate the extent of DNAPLs within three features/areas. MDEQ personnel were present during excavation activities. The three feature/area investigated were:

1. a concrete sump (labeled "oil dumping tanks" on historical Sanborn maps);
2. a suspected burial area; and
3. the trace of two above-ground storage tanks.

The approximate locations of these features/areas are shown on Figure 5-9.

Three walls of the rectangular concrete sump were found during excavation activities. Although the fourth wall was not found, excavation proceeded to a point where native soils were encountered in the subsurface. The sump is approximately 55 feet by 21 feet by 12 feet deep and contains gravelly fill material saturated with oily water.

The suspected burial area was apparently some type of wooden substructure, although the function it served is unclear from historical aerial photographs. Unlike the concrete sump, however, it is not believed to have been a component of the wood treating process. Two walls constructed of treated timbers and a wooden floor were encountered during excavation activities. Soils within the sump exhibited odors and staining, but free liquids were confined to the timbers themselves.

Although the concrete slabs on which the two above-ground storage rested were found during excavation activities conducted, no affected soils or free liquids were encountered. MDEQ concurred that no remedial action is necessary in this area.

5.2.2 Removal of Free Product and Creosote-Saturated Materials

Prior to excavation and removal of materials within the former Process Area, the asphalt cover above the concrete sump and the concrete slab above the wooden substructure will be removed. Excavation will then proceed with a backhoe, with excavated materials loaded directly into trucks for transportation offsite and disposal at an acceptable location. Removal will be limited to the free product and creosote-saturated materials within, surrounding, and beneath the concrete sump and the wooden substructure, including the timbers comprising the wooden substructure.

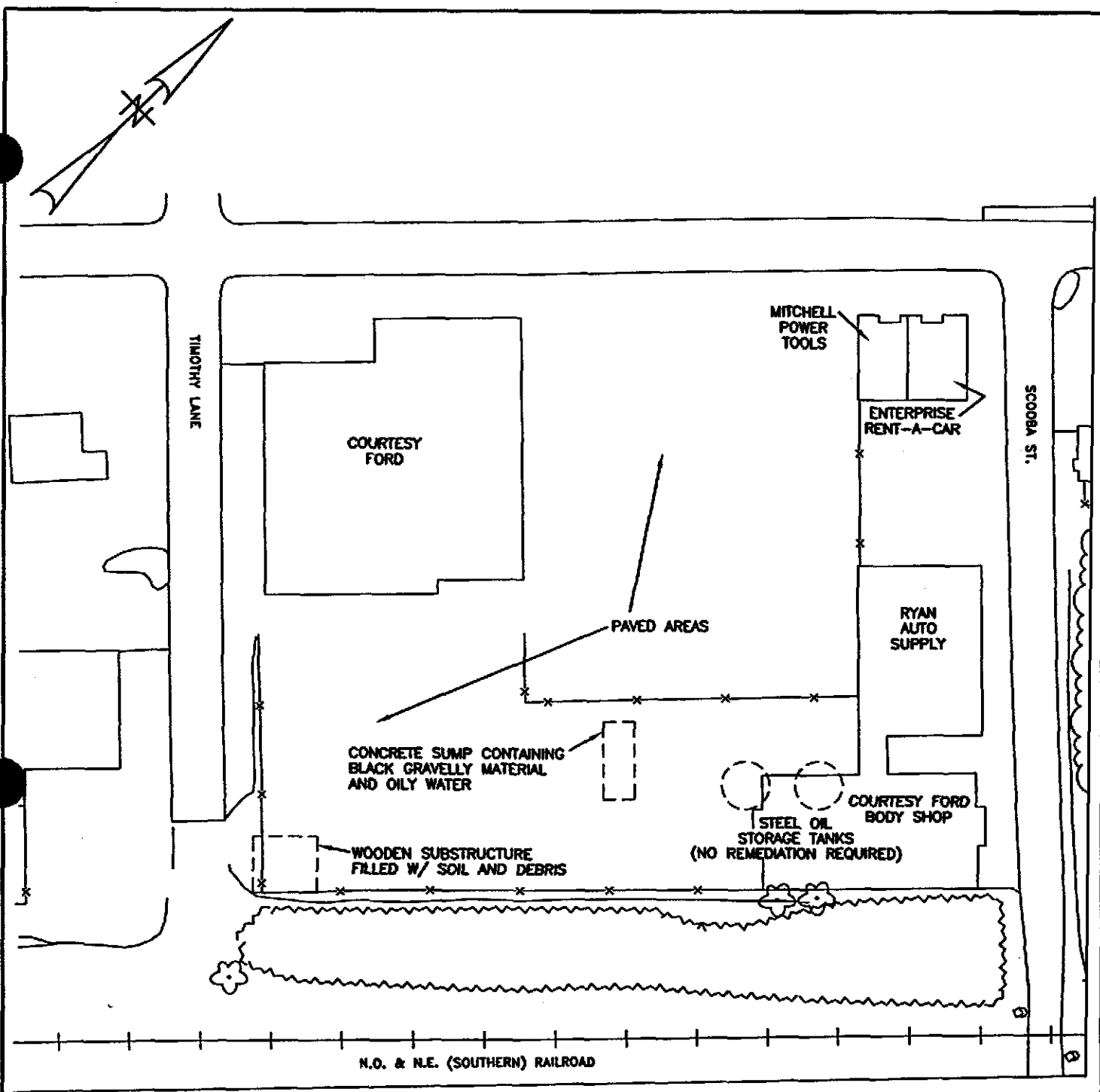

BASE MAP FROM ATLANTIC TECHNOLOGIES, LTD.,
HUNTSVILLE, ALABAMA, APRIL 1, 1996

MICHAEL PISANI & ASSOCIATES
Environmental Management and Engineering Services
New Orleans, Louisiana Houston, Texas

FIGURE 5-9
SOURCE AREAS TO BE REMEDIATED
FORMER PROCESS AREA
FORMER GULF STATES CREOSOTING SITE
HATTESBURG, MISSISSIPPI

SCALE: 1"=100'

DWG. NO.: 21-04/235A

The concrete sump and the excavation for the wooden substructure will be backfilled with clean fill materials.

5.2.3 Capping of Affected Soils

The Courtesy Ford parking lot, (i.e., the site of the former Process Area) will be capped to preclude direct contact with and to minimize the potential for infiltration of precipitation through affected soils left in place. In order to provide maximum protection and allow for continued use of the area as a parking lot, an alternative cap consisting of a water-impervious liner covered with asphalt will be installed. The liner used will be a composite geotextile material that consists of two layers (top and bottom) of 6 ounces/square yard non-woven polyester bonded to 15 mils of polyethylene vinyl acetate. Once the subgrade has been prepared, the water-impervious geotextile will be placed atop the former Process Area, with approximately 12 inches of overlap at the joints between panels. A 2-inch asphalt layer will be placed atop the geotextile, which is heat resistant up to a temperature of 400 degrees Fahrenheit.

5.2.4 Monitored Natural Attenuation

The source removal and capping described above will eliminate or greatly reduce the potential for leaching of site constituents to ground water. The MDEQ-approved *Ground Water Monitoring Plan* outlines a program for demonstrating natural attenuation of ground water constituents in the Process Area plume.

5.3 Southern Railroad Track Area

The remedial action objectives for the Southern railroad track area are to: 1) remove free product and creosote-saturated materials from within and beneath drainage ditches; 2) eliminate the potential risks posed by direct contact with affected soils and minimize the potential for infiltration of precipitation through affected soils; and 3) demonstrate that natural attenuation of constituents in ground water is occurring.

Free product and creosote-saturated soils within and beneath drainage ditches in the Southern Railroad track area will be removed and transported offsite for disposal at an acceptable location. MDEQ has agreed that affected soils outside of the ditches may be removed and transported offsite for disposal at an acceptable location, or may be capped and left in place if appropriate easements/deed restrictions can be obtained. Ground water monitoring necessary to demonstrate natural attenuation of site constituents will also be performed.

5.3.1 Removal of Affected Soils

The approximate area containing affected soils to be removed and/or capped is shown on Figure 5-10. Prior to commencing soil removal activities, this area will be cleared of brush and other vegetation. Excavation of soils within and beneath drainage ditches will then proceed with a trackhoe, with excavated materials loaded directly into trucks for transportation offsite and disposal at an acceptable location. Excavation will continue until all free product and creosote-saturated soils have been removed.

If KMC can obtain appropriate easements/deed restrictions from the City of Hattiesburg and Norfolk Southern Railroad, affected soils outside the ditch will be left in place and capped as described in Section 5.3.2. If not, MDEQ has requested that the upper 3 feet of soil between the ditches and the railroad berm be removed, and that the area be backfilled with compacted clay overlain with appropriate drainage layers. If KMC is unable to obtain the necessary easements/deed restrictions to leave affected soils in place, KMC will attempt to obtain permission from the City and Norfolk Southern to conduct soil removal activities.

5.3.2 Capping of Affected Soils

The ditch excavations, and any other excavated areas, will be backfilled with clean fill material. A water-impervious liner will be placed in the ditches, then the ditches will be lined with reinforced concrete.

Other portions of the Southern Railroad track area where affected soils are left in place will also be capped. First, the area will be graded such that drainage flows toward the concrete-lined ditches. A water-impervious^{XXXX} will be placed atop affected soils, then covered with non-woven geotextile fabric or a sand layer for drainage. A layer of crushed rock similar to railroad ballast will be placed atop the drainage layer to provide protection of the drainage layer.

5.3.3 Monitored Natural Attenuation

Affected soils within the Southern railroad track area may or may not contribute to affected ground water within the former Process Area plume. The soil removal and capping described above will eliminate or greatly reduce the potential for leaching of site constituents to ground water. The MDEQ-approved *Ground Water Monitoring Plan* outlines a program for demonstrating that natural attenuation of constituents in ground water is occurring.

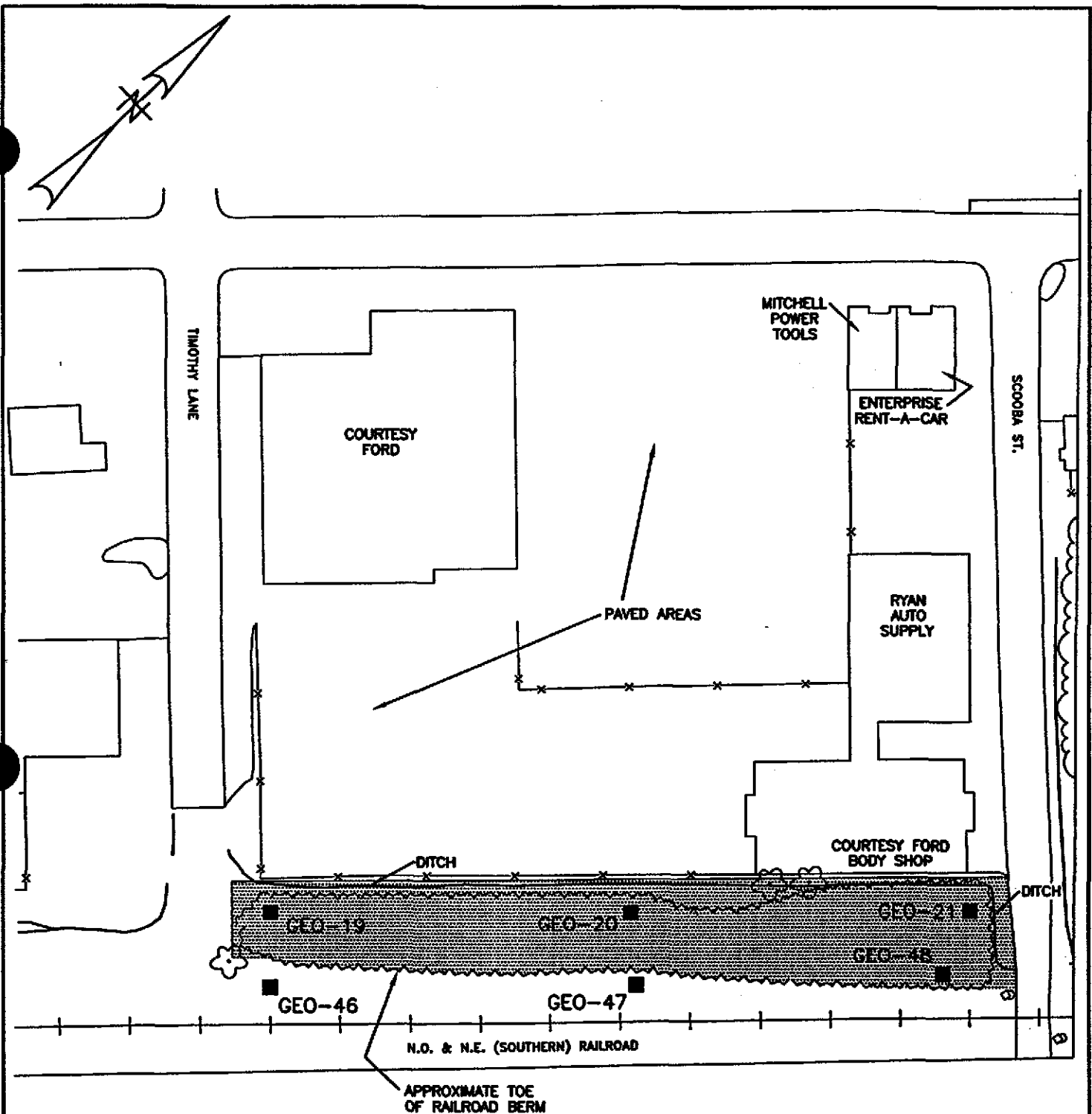

LEGEND

■ SOIL SAMPLING LOCATION



BASE MAP FROM ATLANTIC TECHNOLOGIES, LTD.,
HUNTSVILLE, ALABAMA, APRIL 1, 1996

MICHAEL PISANI & ASSOCIATES
Environmental Management and Engineering Services
New Orleans, Louisiana Houston, Texas

SCALE: 1"=100'

DWG. NO.: 21-04/277A

FIGURE 5-10
APPROXIMATE EXTENT OF SOIL TO BE REMOVED AND/OR CAPPED
SOUTHERN RAILROAD TRACK AREA
FORMER GULF STATES CREOSOTING SITE
HATTIESBURG, MISSISSIPPI

6.0 Contingency Plan

A Contingency Plan has been developed and is included as Appendix E of this document. The plan establishes procedures to respond to the potential migration of existing ground water plumes associated with the Gordon's Creek Fill Area, the former Process Area, and the northeast drainage ditch. Should target constituents be detected in plume-defining wells at concentrations exceeding Tier 1 Target Remediation Goals for three consecutive sampling events, KMC will, within 60 days, submit a plan for assessment activities for MDEQ review and approval. At the completion of assessment activities, KMC will submit a report documenting assessment results and proposing further action, if necessary.